



**GREEN MOUNTAIN WATER & SANITATION DISTRICT
RULES AND REGULATIONS**

Amended and Restated: February 10 2026

**GREEN MOUNTAIN WATER & SANITATION DISTRICT
RULES AND REGULATIONS**

TABLE OF CONTENTS

ARTICLE 1—Definitions	1
ARTICLE 2—Purpose and Scope of Rules and Regulations	7
2.1 General Purpose and Authority	7
2.2 Scope of Rules and Regulations.....	7
2.3 Rules and Regulations of Other Governmental Entities.....	7
2.4 Rules of Construction	7
2.5 Conflicts	8
2.6 Amendment, Modification, Waiver or Suspension	8
2.7 Severability	9
ARTICLE 3—Description of District and Powers	10
3.1 Description of the District	10
3.2 Fees, Rates and Charges.....	10
3.3 Penalties and Perpetual Lien	10
3.4 Eminent Domain.....	10
ARTICLE 4—Ownership, Construction, Operation, Maintenance and Inspection of Facilities.....	11
4.1 Policy	11
4.1.1 Hazardous Conditions.....	11
4.2 District Facilities.....	11
4.2.1 Relationship with Denver Water and Metro	11
4.2.2 Ownership of District Facilities	11
4.2.3 Construction.....	12
4.2.4 Inspection, Approval and Acceptance of District Facilities.....	12
4.2.5 Operation and Maintenance.....	12
4.2.6 Special Maintenance.....	13
4.3 Service Lines	13
4.3.1 Ownership.....	13
4.3.2 Indemnification.....	13
4.3.3 Construction	13
4.3.3.1 Existing Service Lines.....	14
4.3.3.2 Accessory Dwelling Units	14
4.3.3.2.1 Sewer Service Connection.....	14
4.3.3.2.2 Water Service Connections	14
4.3.4 Stub-Ins.....	14
4.3.5 Inspection	14
4.3.6 Operation and Maintenance	15
4.4 Relationship with Other Governmental Entities	15
4.5 Compliance Inspections	15
4.6 Limitation of Liability of District	15
4.7 Homeowner’s Insurance	16
4.8 Right of Entry.....	16

4.9	Contractor Qualifications and Requirements	16
4.9.1	Contractor Bonding/Responsibilities.....	16
4.9.2	Insurance/Bond	17
4.9.3	Plumbers Licenses not Transferable.....	17
4.9.4	Workers' Compensation.....	17
4.10	Confined Space Program	17
ARTICLE 5—General use of System and Application for Service		19
5.1	Who May Use	19
5.1.1	Permits Required	19
5.1.2	Separate Permits	19
5.2	Authority to Uncover, Use or Alter System.....	19
5.3	Inclusions of Property into District Boundaries	19
5.4	Extraterritorial Service	20
5.5	Requirements for New Service.....	20
5.6	Requirements for Service.....	20
5.6.1	Conditions of Service	21
5.6.1.1	Construction, Extension and Oversizing of Facility/Main for Service	21
5.6.1.2	Construction, Extension and Oversizing of Facility/Main for Future Development.....	21
5.6.1.2.1	Adjacent Developments	21
5.6.1.2.2	Connecting Mains	21
5.6.1.2.3	Benefitted Property	22
5.6.1.2.4	Oversize	22
5.6.1.3	Removed as of 11/14/2023.....	22
5.6.1.4	Conveyance of Property Rights	22
5.6.1.5	Reimbursement for Condemnation	22
5.6.1.6	Development Agreement.....	22
5.6.2	Denial or Revocation of Application.....	22
5.6.3	Approval of Application/Tap Permit.....	22
5.6.4	Will Serve Letters.....	22
5.6.4.1	Applications.....	23
5.6.4.2	Reserved Capacity	23
5.6.4.3	Outstanding Will Serve Letters.....	23
5.6.4.4	Term	23
5.6.4.5	Limitations.....	23
5.6.4.6	Denial or Revocation of Application.....	24
5.7	Change to Property, Buildings, Use of Property, Equipment or Service	24
5.7.1	Moved, Demolished or Destroyed Buildings.....	24
5.7.2	Change to Use of Property, Equipment or Service	24
5.8	Prohibited Acts.....	25
5.8.1	Unauthorized Persons	25
5.8.2	Unauthorized Connection to System.....	25
5.8.3	Prohibited Use of System	25
5.8.4	Illegal Acts.....	25
5.9	Forfeitures.....	26
5.9.1	Revocation of Service	26
5.9.2	Failure to Connect	26

5.9.3	Revocation of Tap Rights	26
5.10	Non-Transferability of Taps and Tap Permits.....	26
5.11	Limitation on Assignment	26
5.12	Penalties.....	26
5.13	Reimbursement of District Costs	26
ARTICLE 6—Use of the Sewer System		28
6.1	Authority to Uncover, Use or Alter Sewer System.....	28
6.2	Responsibilities of the Owner	28
6.3	Prohibited Acts.....	28
6.3.1	Surface Water Runoff and Groundwater	28
6.3.2	Cesspools and Septic Tanks	29
6.3.3	Industrial Waste.....	29
6.3.4	Other Wastes.....	29
6.4	Classification of Wastes.....	29
6.5	Discharge of Special Sewage	30
6.5.1	Approval Required.....	30
6.5.2	Surcharge.....	30
6.5.3	Monitoring Manhole or Vault Requirement.....	30
6.6	Pretreatment and Interceptor Requirements.....	31
6.6.1	Pretreatment: General Requirements.....	31
6.6.2	Requirement for Grease and Sand/Oil Interceptors	31
6.6.3	District Approval	31
6.6.4	Inspection and Enforcement of Sewage Discharge Regulations	32
6.6.4.1	Periodic Inspections and Fees	32
6.6.4.2	Authorization to Enter Upon Private Property.....	32
6.6.4.3	Unauthorized Discharge of Sewage	32
6.7	Compliance with Other Applicable Regulations.....	32
ARTICLE 7—Use of the Water System		33
7.1	Authority to Uncover, Use or Alter Water System.....	33
7.2	Responsibilities of the Owner	33
7.3	Provision of Service	33
7.4	General.....	33
7.5	Cross-Connection/Dual Supply.....	33
7.6	Fire Protection Sprinkler System.....	34
7.7	Compliance with Other Applicable Regulations.....	34
ARTICLE 8—Fees, Rates and Charges		35
8.1	General.....	35
8.2	Application of this Article.....	35
8.3	Schedule of Fees, Rates and Charges.....	35
8.3.1	Water Surcharge.....	35
8.3.2	Sewer Surcharge.....	35
8.4	Adjustment of Fees, Rates and Charges.....	35
8.5	Rebate Agreements/Fees.....	35
8.6	Payment of Fees, Rates and Charges	36

8.6.1	Accounting Adjustments.....	36
8.6.2	Meter Adjustments.....	36
	8.6.2.1 Meter Testing	36
	8.6.2.2 Remote Meter Failure	36
8.6.3	Construction Water Charge.....	36
8.6.4	Unauthorized Use by District Customers	37
8.7	Billing.....	37
	8.7.1 Rental or Leased Properties	37
8.8	Due Date.....	38
8.9	Responsibility for Costs	38
8.10	Perpetual Lien/Foreclosure.....	38
8.11	Penalties for Late Payment or Non-Payment.....	38
ARTICLE 9—Enforcement, Violations and Penalties		39
9.1	Violations.....	39
9.2	Enforcement Remedies	39
	9.2.1 Notification of Violation	39
	9.2.2 Penalties for Violations.....	39
	9.2.2.1 Penalty.....	39
	9.2.2.2 Late Fee	39
	9.2.2.3 Interest	39
	9.2.2.4 Perpetual Lien/Foreclosure.....	39
	9.2.2.5 Certification of Amount to County Treasurer	40
	9.2.2.6 Revocation of Service	40
	9.2.2.7 Revocation of Tap Permit.....	40
	9.2.2.8 Civil Liability.....	41
	9.2.2.9 Criminal Liability.....	41
	9.2.2.10 Other Remedies Provided at Law.....	41
	9.2.2.11 Reimbursement of District Costs.....	41
9.3	Hearing and Appeal Procedures.....	41
	9.3.1 General	41
	9.3.2 Appeal to District Management	42
	9.3.3 Hearing Before Board of Directors	42
	9.3.3.1 Notice	42
	9.3.3.2 Conduct of Hearing	42
	9.3.3.3 Written Determination.....	42
	9.3.3.4 Board of Directors Determination Final.....	43
9.4	Emergencies	43

APPENCICES: See Table of Contents following Page 43

ARTICLE 1 – DEFINITIONS

Unless the context specifically states otherwise, the meaning of the following terms when used herein shall be as set forth below:

- 1.1 Accessory Dwelling Unit.** A dwelling unit that is attached or detached from the primary residence and contain facilities for sleeping, cooking, and sanitation and in which one or more persons could reasonably reside on a permanent and non-transient basis. Cooking facilities include any or all, of the following: sink, range, stove, conventional oven, microwave oven. Sanitation facilities include any or all, of the following: toilet, bath, shower.
- 1.2 Actual Cost.** Shall mean all direct costs applicable to the construction of a given facility, including, but not limited to, surveys, construction, preliminary and design engineering, inspection, administrative and legal costs, regulatory agency fees, a one- (1) year’s maintenance bond, all required easements for land, plan approval fees, “as-built” drawings and other costs necessary for completion.
- 1.3 Applicant.** Shall mean any Person who applies to the District for Service or for Connection to or disconnection from the District’s Facilities, who applies for a Main extension or other such Service or who attempts to have real property included within or excluded from the District.
- 1.4 Board or Board of Directors.** Shall mean the duly elected or appointed Board of Directors of the District which acts as the governing body of the District.
- 1.5 B.O.D.** Denoting 5-day Biochemical Oxygen Demand, shall mean the amount of oxygen that is utilized in the aerobic decomposition of Sewage under laboratory procedures in accordance with the current “Standard Methods for the Examination of Water and Wastewater.”
- 1.6 Connection.** See “Tap or Connection” in Section 1.53.
- 1.7 Consultant.** Shall mean any Person who provides advice within a field of specialized knowledge or training and performs professional, executive or managerial services for the District.
- 1.8 Contractor.** Shall mean any Person who performs work or furnishes materials to property within the District or undertakes to construct, alter, move, demolish, repair, replace, excavate or add to any District Facilities or Service Lines.
- 1.9 Cross-Connection.** Shall mean any physical arrangement whereby the District’s Water System is connected, directly or indirectly, with any non-potable or unapproved water supply system, sewer drain, well, conduit, pool, reservoir, plumbing fixture or other device which contains or may contain any contaminated water, liquid or other waste of unknown, non-potable or unsafe quality that could impart a contaminant into the Water System as a result of backflow.
- 1.10 Customer.** Shall mean any Person who is connected to or physically using the District’s Water System or Sewer System or authorized to connect to the District’s Water System or Sewer System under a Tap Permit issued by the District.

- 1.11 Denver Rules.** Shall mean the Operating Rules of the Board of Water Commissioners for the City and County of Denver as the same may be amended from time to time. The Denver Rules are incorporated by reference herein and are binding upon the District and upon Customers thereof.
- 1.12 Denver Water.** Shall mean the Board of Water Commissioners for the City and County of Denver, which is the sole purveyor providing water to the District, and as such, the District is subject to the Denver Rules.
- 1.13 Developer.** Shall mean any Person who is engaged in development, redevelopment or subdivision of real property within the District's Service Area.
- 1.14 District.** Shall mean the Green Mountain Water and Sanitation District, a quasi-municipal corporation and political subdivision of the State of Colorado.
- 1.15 Engineer.** Shall mean the Person, or duly authorized representative thereof, who has contracted to do engineering work for the District.
- 1.16 District Facilities or Facilities.** Shall mean the Water System and Sewer System and all improvements and appurtenances thereto constructed by or for the District and which have been accepted by and are owned by the District. District Facilities shall include Regional Facilities and may include Local Facilities after final acceptance thereof by the District.
- 1.17 Emergency.** Shall mean an immediate threat of harm to property, or the public health, safety or welfare.
- 1.18 Employee.** Shall have the same meaning as "public employee" in Section 24-10-103(4), Colorado Revised Statutes as it may be amended from time to time.
- 1.19 EQR (Equivalent Residential Unit).** Shall mean any unit that impacts the sewer collection or treatment system the equivalent of a single family residential unit. The base for this schedule is an average detached single-family residence with not more than 3 bedrooms or 2 baths, or its equivalent.
- 1.20 Industrial Waste.** Shall mean the liquid by-products from industrial and manufacturing processes as distinct from Normal Sewage or Special Sewage.
- 1.21 Inspection Fee.** Shall mean a fee imposed by the District to cover the costs incurred by the District in the inspection of tap connections and installations payable to the District at the same time as System Development Fees. If multiple inspections are required because of poor installation or poor scheduling on the part of the Developer, Owner or Contractor, the Manager may charge additional fees based on costs, hourly rates and expenses incurred by the District.
- 1.22 Inspector.** Shall mean the firm, or duly authorized representative, designated by the District to act in its behalf. This item includes an Inspector employed by the Engineer.

- 1.23 Local Facilities.** Shall mean those facilities designed primarily to serve individual developments and includes all facilities necessary to serve the infrastructure of the development. Local Facilities do not include Service Lines.
- 1.24 Main.** Shall mean any Water Main or Sewer Main.
- 1.25 Manager.** Shall mean any Person, or duly authorized representative thereof, retained by the Board to administer and supervise the affairs of the District.
- 1.26 Master Meter Contract.** Shall have the meaning ascribed to it in Section 4.2.1.
- 1.27 Metro.** Shall mean Metro Wastewater Reclamation District Number One.
- 1.28 Metro Rules.** Shall mean the Rules and Regulations of the Board of Directors of the Metro Wastewater Reclamation District Number One as the same may be amended from time to time. The Metro Rules are incorporated by reference herein and are binding upon the District and upon Customers thereof.
- 1.29 Normal Sewage.** Shall mean Sewage which can be treated without pre-treatment and within normal treatment process operating procedures, and which, when analyzed, shows a daily average concentration of not more than 300 milligrams per liter (mg/l) of Suspended Solids and not more than 300 mg/l B.O.D.
- 1.30 Oversize Costs.** This item is applicable to part of the costs of a Water Main or a Sewer Main to be installed within, or for, a subdivision; but for which the District has also assigned a transmission function which results in the need for a larger pipeline. Oversize costs are the difference between the Actual Costs of the size of the line required by the District and the size required to serve the current development proposed by the Developer; however, for purposes of determining oversize, the minimum size shall be assumed to be 12-inch diameter for water and 8-inch diameter for sewer.
- 1.31 Owner.** Shall mean the Person owning the fee interest in property served by or seeking Service by the District.
- 1.32 Person.** Shall mean any individual, firm, company, association, society, organization, partnership, corporation, group, government or subdivision thereof or other entity.
- 1.33 Prohibited Sewage.** Shall mean any toxic or non-biodegradable waste, or any wastes which cannot be treated by conventional treatment processes or any Sewage which may reasonably be anticipated to have a deleterious effect upon the Sewer System or any Persons or property and shall include any Sewage prohibited under the Metro Rules.
- 1.34 Regional Facilities.** Shall mean those facilities generally serving the Service Area as a whole, regardless of location, that are interconnected with other District Facilities as an integral part of the District's Water System or Sewer System.

- 1.35 Rules and Regulations.** Shall mean the Rules and Regulations adopted by the District including all amendments, policies and resolutions.
- 1.36 Sampling.** Shall mean the periodic collection of samples for analysis.
- 1.37 Service.** Shall mean the provision of Water Service or Sewer Service by the District to a Developer, Owner or Customer.
- 1.38 Service Area.** Shall mean the legal boundary within which the District provides Service.
- 1.39 Service Line(s).** Shall mean the Water Service Line or the Sewer Service Line.
- 1.40 Sewage.** Shall mean any liquid waste containing animal or vegetable matter in suspension or solution from residences, commercial buildings, institutions and industrial establishments.
- 1.41 Sewer Main.** Shall mean a District-owned sewer pipeline, carrying sanitary Sewage or approved Industrial Waste only, and shall be installed in a public right-of-way or easement.
- 1.42 Sewer Service.** Shall mean the provision of sewer service by the District to a Developer, Owner or Customer.
- 1.43 Sewer Service Line(s).** Shall mean the privately owned pipe, line, conduit or system of piping and appurtenances thereto used to provide Service from a building to a Sewer Main.
- 1.44 Sewer System.** Shall mean all Sewer Mains, manholes, cleanouts, lift stations and related appurtenances used for collecting, pumping, treating and disposition of Sewage which are owned and operated by the District.
- 1.45 Sewer System Development Fee.** Shall mean a one- (1) time fee designed to provide recovery of capital investments attributable to Regional Facilities of the Sewer System and shall be in the amount set forth in the **SCHEDULE OF FEES, RATES AND CHARGES**, as the same may be amended from time to time.
- 1.46 Shall** is mandatory; **may** is permissive.
- 1.47 Special Connectors Agreement.** Shall have that meaning ascribed to it in Section 4.2.1.
- 1.48 Special Sewage.** Shall mean any Sewage which does not conform to the definition for Normal Sewage, but which can be treated after pre-treatment by the Customer or by utilization of special operating procedures. Pre-treatment shall include the use of interceptors as described in these Rules and Regulations.
- 1.49 Stub-In/Stub-Out.** Shall mean an extension of a Water Main or Sewer Main to beyond the edge of street or parking lot pavement of a property, for the purpose of connecting the property to the Sewer System. This is done for the convenience of the Developer in order to avoid trenching across paving at the time of Connection. Any Stub-In, whether constructed by the District or any Person,

and whether located on private property or in a public right-of-way, shall be considered a part of the Service Line and shall be the Customer's responsibility.

- 1.50 Sump Pump.** Shall mean a pump used to remove water that has accumulated in a sump basin from foundation perimeter drains due to rain or groundwater. Sump pumps are commonly found in the basement of a building.
- 1.51 Suspended Solids.** Shall mean the weight of filterable solids in milligrams present in one (1) liter of Sewage.
- 1.52 System.** Shall mean the District Facilities, Service Lines and all other facilities and appurtenances related to the District's Water System or Sewer System whether owned by the District or any other Person.
- 1.53 System Development Fees.** Shall mean the total of the Water System Development Fee and the Sewer System Development Fee, as applicable.
- 1.54 Tap or Connection.** Shall mean the physical connection of, or the act of connecting, a Service Line to the Water System or the Sewer System, either directly to a Main or a Stub-In/Stub-Out or indirectly through a private line, which Service Line extends beyond the property line to the structure intended to be served, whether or not actually connected to the structure.
- 1.55 Tap Permit.** Shall mean the District's written authorization for Connection to a Water Main, Sewer Main or other District Facilities under the conditions expressed in writing by the District and granting an Applicant a revocable license to use the Water System or Sewer System under the conditions expressed and as provided in the Rules and Regulations of the District, the Denver Rules and the Metro Rules, as applicable.
- 1.56 Total Kjeldahl Nitrogen (TKN).** Shall mean the sum, expressed in parts per million (ppm) or milligrams per liter (mg/L), of free-ammonia nitrogen and organic nitrogen compounds which are converted to ammonia under digestion conditions specified by the Kjeldahl Nitrogen Test Method.
- 1.57 Water Main.** Shall mean a District-maintained and operated water pipeline, carrying potable water only and which shall be installed in a public street or special easement.
- 1.58 Water Service.** Shall mean the provision of water service by the District to a Developer, Owner or Customer.
- 1.59 Water Service Line(s).** Shall mean the privately owned water line extending from the Water Main to a structure to provide Service, and shall include the tap on the Main, corporation cock, curb valve, curb valve box, meter pit, dome and lid (or frame and cover), valve and meter yoke and meter.
- 1.60 Water System.** Shall mean all water Mains and related facilities and appurtenances which are owned and operated by the District and used for delivery of water to Customers.

- 1.61 Water System Development Fee.** Shall mean a one- (1) time fee designed to provide recovery of capital investments attributable to Regional Facilities of the Water System and shall be in the amount set forth in the SCHEDULE OF FEES, RATES AND CHARGES, as the same may be amended from time to time.
- 1.62 Will Serve Letter.** Shall mean a conditional agreement by the District to provide Service to a particular property or properties within the District's Service Area.
- 1.63 Any other term** not herein defined shall be defined as presented in the "Glossary – Water and Sewage Control Engineering," A.P.H.A., A.W.W.A., A.S.C.E. and F.W.S.A., latest editions.

ARTICLE 2 – PURPOSE AND SCOPE OF RULES AND REGULATIONS

- 2.1 General Purpose and Authority.** The purpose of these Rules and Regulations is to provide for the orderly construction, management, operation and control of the public utility systems, facilities and improvements of the District, including additions, extensions and connections thereto. The District is a governmental entity and political subdivision of the State of Colorado and a body corporate with all powers of a public or quasi-municipal corporation which are specifically granted or implied for carrying out the objectives and purposes of the District.

These Rules and Regulations are promulgated and adopted pursuant to the provisions of Section 32-1-1001(1)(m), Colorado Revised Statutes, as amended from time to time.

It is hereby declared that the Rules and Regulations hereinafter set forth will serve a public use and are necessary to ensure and protect the health, safety, prosperity, security and general welfare of the inhabitants of the District.

- 2.2 Scope of Rules and Regulations.** These Rules and Regulations shall be treated and considered as new and comprehensive regulations governing the operations and functions of the District and shall supersede all previous versions of Rules and Regulations as well as informal practices and policies of the District, which practices and policies may be in conflict with the provisions hereof.

- 2.3 Rules and Regulations of Other Governmental Entities.** No Person or entity shall discharge any pollutant in violation of any applicable regulation, including maximum pollutant levels, established by any local, state or federal agency, including but not limited to the Colorado Department of Health and Environment, the Water Quality Control Commission and the Environmental Protection Agency, as the same may be amended from time to time. If, as a result of any such violation, the District is subject to any civil or criminal liability, any fines, fees or penalties or other costs assessed against the District and any costs incurred by the District to defend against such liability, including but not limited to legal, engineering and administrative fees, shall be owed and paid to the District by such violator.

The District receives water from Denver Water pursuant to a Master Meter Contract with Denver Water under which the District is obliged to abide by the Denver Rules as they may from time to time be amended. The Denver Rules are incorporated by reference herein and are binding upon the District and upon Customers thereof.

The District's Sewage System is connected to the Metro Interceptor Sewer System, through which Sewage is conveyed to the Metro Sewage treatment facility. Sewage treatment is provided by Metro via contract with the District, under which the District is obliged to abide by the Metro Rules as they may from time to time be amended. The Metro Rules are incorporated by reference herein and are binding upon the District and upon Customers thereof.

Developers, Owners and Customers shall abide by all applicable local, state and federal laws, policies, codes, rules and regulations, as the same may be amended from time to time.

- 2.4 Rules of Construction.** The Rules and Regulations of the District are promulgated pursuant to statute in the exercise of the Board's discretion to provide a tool for the District's Manager and for the orderly provision of essential services. These Rules and Regulations shall be liberally construed

to effect the general purposes set forth herein, and each and every part hereof is separate and distinct from all other parts. Nothing contained herein shall be so construed as to prejudice or affect the right of the District to secure the full benefit and protection of any law now in effect or any law which may subsequently be enacted pertaining to the affairs of the District. Nothing set forth in or omitted from inclusion in these Rules and Regulations shall be construed to alter, waive or deviate from any grant of power, duty, responsibility, limitation or restriction imposed or conferred upon the District by statutes now existing or amended in the future or under any contract or agreement existing between the District and any other governmental entity. The Board reserves the right, now or in the future, to construe any provision hereof in its sole discretion in order to effectuate lawful purposes of the District and to attempt to ensure orderly and non-discriminatory treatment of all Persons or entities subject to these Rules and Regulations.

The Rules and Regulations constitute guidelines for the benefit of the District and must be complied with by all Consultants, Contractors, Developers, Owners and Customers absent receipt of a proper written waiver from the District. No Person shall obtain, by virtue of the Rules and Regulations, any right or cause of action against the District or its Manager or Consultants arising as a result of the enforcement or lack of enforcement of the Rules and Regulations by the District. Nothing herein shall be deemed to be a waiver of any immunity granted to the District under Colorado law.

- 2.5 Conflicts.** In case of any conflict between any provision of these Rules and Regulations, the District shall be entitled to resolve such conflict in its own favor at the District's sole discretion, it being the intention of the Board that these Rules and Regulations shall be construed or interpreted by the District in such manner so as to maximize the ability of the District to govern and manage the District and its Services and Facilities.

The District has attempted to articulate herein its rules, regulations and policies for the provision of public services and facilities, and for management and operation of the District. From time to time, the Board may adopt policies reflected in the minutes of meetings for the District or reflected in resolutions of the Board. To the extent any policy found in minutes of District meetings pre-dates and conflicts with any resolution of the Board, the resolution shall be deemed to supersede the minutes, unless the Board determines otherwise after such conflict is brought to the attention of the Board. To the extent policies found in minutes of meetings post-date resolutions of the District and conflict with such resolutions, the policy stated in the minutes shall be binding unless the Board determines otherwise after such conflict is brought to the attention of the Board. The Board shall have the right, at all times, to repeal and re-enact resolutions of the Board unless any resolution specifically states that it is not subject to repeal and such statement is found to be enforceable.

To the extent that any of the District's Rules and Regulations are inconsistent with any valid and applicable regulations promulgated by Metro, Denver Water or any local, state or federal agency, including the Metro Rules and the Denver Rules, the regulations of Metro, Denver Water or the local, state or federal agency shall govern.

- 2.6 Amendment, Modification, Waiver or Suspension.** These Rules and Regulations may be amended, modified, waived or suspended, from time to time, by the District, as it deems appropriate. Neither notice of such amendments, modifications, waivers or suspensions nor public hearing shall be required to be provided by the District prior to exercising its amendment, modification, waiver or suspension powers. The District has the power to revise its Rules and Regulations from time to time

by formal action of the Board and has authority to waive the application of its Rules and Regulations to its own activities, or to the activities of others. Any formal action of the Board to revise, amend or modify these Rules and Regulations shall be deemed incorporated herein notwithstanding whether such revision, amendment or modification is codified herein. Supplemental policies of the District may be adopted from time to time in order to assist the District and its Consultants and Contractors in managing the affairs of the District. The District shall have the sole authority to amend, waive, suspend or modify these Rules and Regulations. Any Person claiming the benefit of such a waiver, suspension or modification shall be required to obtain a written waiver signed by the District Manager. No refusal, failure or omission of the District or its agents to apply or enforce these Rules and Regulations shall be construed as an alteration, waiver or deviation from any grant of power, duty or responsibility, or any limitation or restriction upon the District by virtue of statutes now existing or subsequently amended, or under any contract or agreement existing between the District and any other entity. Any express waiver shall not be deemed an amendment of these Rules and Regulations. However, an express waiver or variance from these Rules and Regulations by the District shall supersede these Rules and Regulations regarding the subject matter of the express waiver. No waiver shall be deemed a continuing waiver.

- 2.7 Severability.** The invalidity or unenforceability of any portion or previous version of these Rules and Regulations shall not affect the validity or enforceability of any other portion or provision. Any invalid or unenforceable portion or provision shall be deemed severed from these Rules and Regulations and the balance of these Rules and Regulations shall be construed and enforced as if these Rules and Regulations did not contain such invalid or unenforceable portion or provisions.

ARTICLE 3 – DESCRIPTION OF DISTRICT AND POWERS

- 3.1 Description of the District.** The District is a quasi-municipal corporation and political subdivision of the State of Colorado that was organized with the authority to provide certain services to Developers, Owners and Customers within the Service Area of the District. The District derives its power from the Special District Act, Sections 32-1-101 *et seq.*, Colorado Revised Statutes, as the same may be amended from time to time.
- 3.2 Fees, Rates and Charges.** The District has the power to charge various fees, rates, tolls, charges and penalties, and to impose taxes, for services and facilities provided by the District. Additional provisions regarding fees, rates, tolls and charges are contained in Article 8 of these Rules and Regulations.
- 3.3 Penalties and Perpetual Lien.** Reasonable penalties may be fixed for any delinquency including interest on delinquent fees and reasonable attorney’s fees and costs of collection pursuant to state law. The District expressly reserves the right to impose all penalties permitted under state law as appropriate. The failure of a Developer, Owner or Customer to pay fees, rates, tolls, charges and penalties imposed by the District creates a perpetual lien on the affected property and a right for the District to foreclose on that lien. The District expressly imposes a perpetual lien pursuant to state law for failure to pay or for delinquent payment of any rate, fee, toll, charge or penalty assessed by the District pursuant state law. The District exercises such powers for the overall benefit of the District and reserves the right to exercise its discretion on a case-by-case basis in determining whether to file a statement of such lien and foreclose it. Additional provisions regarding violations, enforcement and penalties are contained in Article 9 of these Rules and Regulations.
- 3.4 Eminent Domain.** The District has powers of eminent domain and dominant eminent domain pursuant to Section 32-1-1004(4), Colorado Revised Statutes and may exercise those powers as permitted by law.

ARTICLE 4 – OWNERSHIP, CONSTRUCTION, OPERATION, MAINTENANCE AND INSPECTION OF FACILITIES

4.1 Policy. The District is responsible for the, inspection, operation, and maintenance of the District Facilities in a sound and economical manner; it shall not be liable or responsible for inadequate treatment of Sewage, water or interruption of Service brought about by circumstances beyond its control.

4.1.1 Hazardous Conditions. No member of the GMWSD staff is allowed to conduct any type of work in or around possible hazardous materials and or hazardous conditions. A hazardous material is any item or agent (biological, chemical, radiological, and/or physical) that has the ability to cause harm to humans, animals, or the environment. Hazardous Conditions refers to the presence on, in or about the Property, soil, area (including ground water) of Hazardous Materials, the concentration, condition, quantity, location or other characteristic of which fails to comply with the standards applicable, relevant, or appropriate under applicable environmental laws, state of Colorado laws, OSHA laws and industry standards

4.2 District Facilities.

4.2.1 Relationship with Denver Water and Metro. Water Service is provided within the District pursuant to a master meter contract with Denver Water (the “Master Meter Contract”).

The District treats Sewage pursuant to a Special Connectors Agreement with Metro (the “Special Connectors Agreement”).

Subject to the Master Meter Contract, the Water System which has been constructed within the District is the property of the District, unless an agreement with the Person or entity which constructed them expressly provides otherwise. Subject to the Special Connectors Agreement, the Sewer System which has been constructed by the District or accepted for operation and maintenance pursuant to these Rules and Regulations is the property of Metro or of the District as provided by contract, unless an agreement with the Person or entity which constructed them expressly provides otherwise. These rules shall control ownership whether the components of the Water System or Sewer System are constructed or financed by the District, Metro, Denver Water or by any other Person.

4.2.2 Ownership of District Facilities. The District shall own the District Facilities, but not Water Service Lines and Sewer Service Lines, unless otherwise provided in the Master Meter Contract or Special Connectors Agreement, provided that the District Facilities not constructed by the District have been finally accepted by the District as further described in these Rules and Regulations. The District may only accept ownership (including maintenance) responsibilities for existing and new Local Facilities (including Mains), which have been formally conveyed to and finally accepted by the District in compliance with these Rules and Regulations. Said ownership will remain valid whether the Local Facilities (including Mains) are constructed, financed, paid for or otherwise acquired by the District or by other Persons. The Developer shall dedicate to the District, without charge, all necessary easements for such Local Facilities.

4.2.3 Construction. The District has the sole authority to plan, finance, design and construct or acquire all District Facilities. The District will only construct facilities or portions thereof when the Board has made a determination that such construction is economically feasible and will not compromise Service to its existing Customers and Owners.

The Developer or Owner may be required to plan, finance, design and construct certain facilities, including Local Facilities, as a condition of Service to their property in accordance with Sections 5.5 and 5.6 of these Rules and Regulations. Such facilities may be constructed pursuant to an agreement with the District and shall be constructed in accordance with these Rules and Regulations, plans and specifications approved by the District's Engineer and in accordance with the STANDARDS, as the same may be amended from time to time, which are available upon request from the District. The Owner or Developer shall pay the Actual Cost of all such facilities as approved by the District. Local Facilities may, after completion and subject to any applicable warranty requirements, be accepted for ownership, operation and maintenance by the District in accordance with these Rules and Regulations.

4.2.4 Inspection, Approval and Acceptance of District Facilities. Upon completion of construction of facilities by the Developer or Owner pursuant to this Section 4.2.4 of these Rules and Regulations, the Developer or Owner may apply to the District for initial acceptance and inspection of such facilities. The Owner or Developer shall enter into the "Conveyance and Acceptance of Utilities and Facilities Agreement" with the District and provide as-built drawings, specifications of the facilities, appropriate lien waivers for all work performed and all other requirements in conformance with the agreement. The Owner or Developer shall warrant the constructed facilities for a period of one (1) year from the date of initial acceptance by the District. After expiration of the one- (1) year warranty period, the Owner or Developer shall apply to the District for final acceptance of such facilities. After the District grants final acceptance for the facilities, ownership of such facilities shall be transferred to the District.

4.2.5 Operation and Maintenance. The District shall be responsible for the maintenance, operation, repair and replacement of the District Facilities constructed by or for the District, provided that District Facilities not constructed by the District have been granted final acceptance by the District as further described in Section 4.2.4 of these Rules and Regulations. Until such time as final acceptance has been granted for facilities, the Developer or Owner shall be responsible for the maintenance, operation, repair and replacement of the facilities. All repair or replacement work that is covered under the warranty shall be performed by the Developer or Owner at its cost with District oversight and inspection. All other costs incurred by the District due to the actions of any Developer, Owner, Customer or other third party, including but not limited to legal, engineering and administrative fees, will be paid to the District by such Developer, Owner, Customer or other third party.

4.2.6 Special Maintenance. When the District identifies portions of the District Facilities which require preventive maintenance more than once every three (3) years, and when the District's Customers who are creating the need for extra maintenance can be identified, the District may, to the extent practicable, require those Customers to pay a surcharge

which prorates the added cost of preventive maintenance to the benefit received by the individual Customer.

4.3 Service Lines.

4.3.1 Ownership. The Developer, Owner or Customer shall own and be responsible for the construction, installation, connection, maintenance, repair and replacement of the Service Lines and related appurtenances from the Main to the structure to which the Service Line is attached in conformity with these Rules and Regulations. All costs and expenses incident to the construction, installation, connection, maintenance, repair or replacement of Service Lines and related appurtenances from the Mains to the structures which the Service Lines serve shall be borne by the Developer, Owner or Customer.

After inspection and approval of Service Line construction, ownership of the meter, as well as calibration and maintenance responsibilities for the same, shall be assumed by the District. Only District personnel shall be authorized to access meters. The Developer, Owner or Customer shall ensure that the curb valve, meter pit and lid stay visible and accessible. Notwithstanding the Customer or Owner's responsibility for repairs or replacements as set forth above, the District has the exclusive right to operate the curb valve.

Any Service Line shall be the property of the Developer, Owner or Customer. This rule shall not be changed by the fact that the District may construct, finance, pay for, repair, maintain or otherwise affect the Developer's, Owner's or Customer's Service Line. The Developer's, Owner's or Customer's ownership of the Service Line shall not entitle the Developer, Owner or Customer to make unauthorized uses of the District's Water System or Sewer System. All uses of the Service Line or its appurtenances at any time after the initial Connection to the District's Water System or Sewer System shall be subject to these Rules and Regulations.

4.3.2 Indemnification. The Developer, Owner or Customer shall indemnify the District for any loss or damage that may directly, or indirectly, be occasioned by the construction, installation, connection, maintenance, repair or replacement of a Service Line both during construction and perpetually thereafter.

4.3.3 Construction. A separate and independent Service Line shall be provided for every building, including each unit of a duplex or townhouse and, except as otherwise provided herein or as otherwise agreed to in writing by the District, shall be installed at the expense of the Developer or Owner, except as otherwise provided herein or as otherwise agreed to in writing by the District.

Each commercial structure hereafter constructed shall have an individual Service Line and Connection.

Service Lines shall be constructed and installed in accordance with plans and specifications approved by the District's Engineer and the District STANDARDS. The Developer or Owner shall pay the Actual Cost of all Service Lines. The District may, at its

sole discretion, oversee installation of Service Lines prior to the commencement of Service.

4.3.3.1 Existing Service Lines. Existing Service Lines may be used in connection with new buildings only when found on examination by the District to meet all the requirements of these Rules and Regulations and the STANDARDS and payment of any additional fees has been received by the District, if required.

4.3.3.2 Accessory Dwelling Units. If the structure is considered an ADU:

4.3.3.2.1 Sewer Service Connection. A separate sewer service connection to an ADU is required.

4.3.3.2.2 Water Service Connection. A separate water service connection to an ADU is required.

4.3.4 Stub-Ins. The District may permit the installation of Service Stub-Ins prior to street paving and prior to actual building construction. Upon payment of required fees, the District will provide the Owner with a “Stub-In” application for processing by Denver Water or Metro, as applicable. It shall be the Applicant’s responsibility to comply with the Denver Rules or Metro Rules as applicable. Stub-ins shall be identified with engraved “W” for water and “S” for sewer on the curb and located on District as-built maps.

4.3.5 Inspection. Applicants for Service shall notify the District when the Service Lines have been completed and when Connection is to be made to the District’s Mains so that an inspection can be made. Notice of no less than three (3) business days is required. No Service Line shall be connected to District Mains until after inspection and approval by the District.

The repair or replacement of a Service Line within the District shall not proceed without the Contractor or Owner first obtaining a Service Line Repair Permit as provided in Section 4.9.1. All repairs or replacements of Service Lines are subject to inspection and approval by the District prior to either backfill or, if there is no excavation for line replacement, the conclusion of the contract for repair/replacement of a Service Line. When trenchless technology (e.g. pipe burst, pipe lining) is used to repair or replace a Service Line within the District, the Contractor or Owner must make a video inspection of the Service Line and deliver it to the District for review via a web link or DVD at least two (2) business days before starting the repair or replacement work.

Non-compliance with this Section may result in the uncovering and re-inspection of Service Lines at the expense of the Owner or Developer.

4.3.6 Operation and Maintenance. The Owner shall be responsible for maintaining the Service Line and related appurtenances from the Main to the structure to which the Service Line is attached in conformity with these Rules and Regulations. Leaks, stoppage or breaks in such Service Line will be repaired by the Owner within a reasonable period of the time after notification of such condition by the District or discovery of such condition by the Owner.

If the District, in its sole discretion, objectively believes that an Emergency exists related to a Service Line or that progress satisfactory to the District toward repairing a leak, stoppage or break in a Service Line has not been completed within a reasonable time period, the District may take any reasonable actions to remediate the Emergency in accordance with Section 9.4, including but not limited to revoking Service and disconnecting any Service Line from the District Facilities. During an Emergency, or in the event satisfactory progress has not been made, the District shall have the express right to enter onto the Owner's property and effect any repairs or remediation necessary to abate the Emergency, to collect its costs, including but not limited to legal, engineering and administrative fees, from the Developer, Owner or Customer and to place a lien against the property to secure payment of such costs. Permission to enter onto the property and effect repairs and remediation and agreement to reimburse the District for costs is expressly given in partial consideration for the provision of Service by the District. The District will provide notice to an Owner prior to entering private property where such notice is possible and reasonable in the District's sole discretion.

- 4.4 Relationship with Other Governmental Entities.** The District has entered into agreements with other governmental entities which relate to its provisions of Service and may from time to time enter into additional agreements of this nature. The District's Developers, Owners and Customers are hereby put on the notice of the existence of such agreements and advised that pursuant to such agreements additional fees, rates, tolls, charges and penalties may be assessed to the District's Developers, Owners and Customers by the governmental entities that are a party to those agreements.
- 4.5 Compliance Inspections.** In addition to the inspection of newly installed or repaired/replaced facilities as discussed in Section 4.3 of these Rules and Regulations, the District reserves the right to enter upon all properties, including reasonable access to all District meters and Facilities within the Developer, Owner or Customer's structure, upon notice provided by the District, at any reasonable time to inspect any facility related to the provision of Service by the District for compliance with these Rules and Regulations or other applicable laws and charge the Developer, Owner or Customer a fee for such compliance inspection.
- 4.6 Limitation of Liability of District.** In partial consideration for receiving Service from the District, the Developer, Owner and Customer each agrees that except as provided by the Colorado Governmental Immunity Act, Sections 24-10-101 *et seq.*, Colorado Revised Statutes, as the same may be amended from time to time ("Colorado Governmental Immunity Act"), no claim for damage shall be made against the District for any reason including, but not limited to the following: blockage in the Sewer System causing the backup of effluent; damage caused by testing of pipelines; breakage of any Main; interruption of Service and the conditions resulting therefrom; breaking of any Main, Service Line, valve or meter; failure of the water supply; shutting off or turning on of water; making of connections or extensions; damage caused by water running or escaping from open or defective faucets and appliances; burst Service Lines and other facilities not owned by the District; damage to water heaters, boilers or other appliances resulting from shutting or turning on of water or inadequate or sporadic pressures; inadequate water delivery, Sewage treatment or interruption of any Services brought about by circumstances beyond its control; or for doing anything to the District Facilities deemed necessary by the District or its agents. Except if required and as provided by the Colorado Governmental Immunity Act, the

District shall have no responsibility for notification to any Developer, Owner or Customer of any of the foregoing conditions. The District reserves the right to temporarily discontinue Service to any property at any time for any reason deemed necessary or appropriate by the District. The District shall have the right to revoke Service to any property for violations of these Rules and Regulations as provided in Section 9.2.2.6 of these Rules and Regulations.

Nothing in these Rules and Regulations may be deemed a waiver by the District of any rights under Colorado law, including but not limited to, the Colorado Governmental Immunity Act. No act or inaction by the District shall be construed as a waiver in whole or in part of the protections provided by the Colorado Governmental Immunity Act unless expressly and formerly resolved by the Board.

4.7 Homeowner’s Insurance. Developers, Owners and Customers of the District shall at all times maintain in full force and effect insurance coverage, whether by rider or otherwise, that is in their opinion adequate to provide coverage for damage incurred to their personal and real property from any back-up, leak or spill of Sewage and any leaking or flooding of Water and which cover, to the extent available, their responsibilities and obligations under these Rules and Regulations.

4.8 Right of Entry. Duly authorized representatives of the District, including but not limited to the Engineer, Consultants, Employees and other personnel authorized by the District, bearing proper credentials and identification, shall be permitted, and are hereby expressly granted the right, to enter upon all properties for the purpose of inspection, observation, measurement, Sampling and testing, repairs or any other reasonable purpose in accordance with the provisions of these Rules and Regulations. As partial consideration for the provision of Service by the District, the Developer, Owner or Customer grants the aforementioned duly authorized representatives of the District the express right to enter upon private property for the purposes stated herein. Access to all District Facilities shall be maintained, and the District shall have the right to access all District Facilities at reasonable times.

4.9 Contractor Qualifications and Requirements.

4.9.1 Contractor Bonding/Responsibilities. In order to prevent damage to the District’s Facilities, Water Service Lines and Sewer Service Lines shall only be installed, repaired or replaced by a bonded Contractor or Owner. Any Water Service Line or Sewer Service Line installation, construction, connection, maintenance, repair or replacement work, design thereof and all materials used in connection therewith shall conform in their entirety to these Rules and Regulations, the requirements of the applicable plumbing code, the applicable regulations of the City of Lakewood and, if appropriate, Denver Water, and all standards and specifications of the District and may require the approval of the District’s Engineer.

Contractors or Owners must submit a completed “Service Line Repair Permit Application” form, the applicable permit fee and all other required supporting documentation to the District and obtain a Service Line Repair Permit from the District prior to initiating any Water Service Line or Sewer Service Line installation, construction, connection, maintenance, repair or replacement work. The only exception to the foregoing is in the case of Emergency work that must be initiated during non-business hours, in which case the Contractor or Owner shall submit a completed Service Line Repair Permit Application to the District on the next business day after work is initiated. Service Line Repair Permits

shall be effective upon issuance of a signed Service Line Repair Permit to the Contractor. The Service Line Repair Permit Application is available at the District office. A Service Line Repair Permit will only be issued by the District after receipt by the District of a completed Service Line Repair Permit Application, all applicable fees and all other required documentation. **The terms, conditions and requirements of the Service Line Repair Permit Application are applicable to all work and are incorporated into these Rules and Regulations.**

- 4.9.2 Insurance/Bond.** Any Contractor or Owner who wishes to install, construct, connect, maintain, replace or repair Service Lines in the District shall purchase and maintain, for the full period of any work, comprehensive general liability/auto liability and other insurance sufficient to protect the District from all claims arising out of the Contractor's work, or the work of any subcontractor or anyone else for whose acts the Contractor may be liable. Each Contractor's insurance coverage shall be sufficiently broad to enable the Contractor to fully indemnify the District and its directors, Employees, agents, Consultants and Engineer (including their officers, directors, employees and agents) against any and all claims arising out of the work performed by the Contractor. The Contractor's insurance coverage shall waive any right of subrogation against the District and directors, Employees, agents, Consultants and Engineer (including their officers, directors, employees and agents). The Contractor shall supply the District proof of insurance. The Contractor shall also supply to the District a bond adequate to guarantee the entire product of the Contractor's work, including backfilling and street repairs, against any failure for a period of one (1) year after approval by the District Inspector.
- 4.9.3 Plumbers Licenses not Transferable.** No licensed plumber shall permit his or her license to be used by any other plumber, but plumbing work contracted for by a licensed plumber may be performed by him or her through journeymen plumbers or apprentices under his or her direct supervision. Work performed through journeymen plumbers or apprentices shall not relieve the licensed plumber from any responsibility.
- 4.9.4 Workers' Compensation.** Any Contractor or Owner who wishes to install, construct, connect, maintain, replace or repair Service Lines in the District shall carry workers' compensation insurance in accordance with the requirements of applicable laws.
- 4.10 Confined Space Program.** Any Contractor or other entity that contracts with the District or otherwise wishes to access the District's confined spaces, shall, as a condition to entry into any of the confined spaces, and to providing services to the District, meet the following requirements:
- a. Acknowledge that the subject facilities are a confined space; and
 - b. Agree to abide by the Occupational Safety and Health Administration (OSHA) regulations for "permit-required confined space" and "non-permit confined space," including the establishment of an OSHA required "permit-required confined space program" (the "Permit Space Program"); and
 - c. Release and indemnify the District in connection with the confined space access.

The District also requires that such Contractor provide the District with a copy of the Contractor's written Permit Space Program that complies with the OSHA regulations.

In addition, as part of the District's confined space requirements, such Contractor shall consult with the District's Engineer regarding any hazards confronted or created in permit-required confined spaces.

ARTICLE 5 – GENERAL USE OF SYSTEM AND APPLICATION FOR SERVICE

5.1 Who May Use. Services will be furnished to property within the Service Area subject to the District's Rules and Regulations, the availability of facilities and capacity and subject to fees, rates, tolls, charges and penalties imposed by the District, Metro and Denver Water. If requested by the District, any Applicant for Service shall furnish satisfactory evidence regarding the status of title to the property to be served. A tax receipt or certification received and signed by the County Treasurer shall be satisfactory evidence.

5.1.1 Permits Required. The right to take and use water distributed and the right to discharge Sewage through the District Facilities shall exist only under a Tap Permit, and no physical Connection may be made or modified to any such Facilities or to any privately or publicly owned extension thereof for any purpose unless a Tap Permit shall have first been obtained authorizing the use for which such a Connection is to be made and the System Development Fee and Inspection Fee has been paid to the District. The Water and/or Sewer Tap Permit Application is available at the District office. A Tap Permit will only be issued by the District after receipt by the District of a completed Water and/or Sewer Tap Permit Application, all applicable fees and all other required documentation. **The terms, conditions and requirements of the Water and/or Sewer Tap Permit Application are applicable to all work and are incorporated into these Rules and Regulations.**

Notwithstanding the issuance of a Tap Permit, the District reserves the full power and authority to determine all matters in connection with the control and use of water from the Water System and Sewage to the Sewer System.

5.1.2 Separate Permits. No water user in or upon any property to which water is supplied under a Tap Permit for such property shall supply or allow water to be supplied for use on any other property unless a Tap Permit for use on such other property shall have been procured. A Tap Permit is required for each and every building using water or discharging Sewage. As applicable, a separate irrigation permit and Tap are required for all commercial structures hereinafter connected. This Tap will be sized by the Developer for the watering of all outdoor landscaping and will not result in additional charges for Sewer Service. The Service Lines to any structure served by the District must be independent of the Service Line to any other structure, except where the structures involved comprise an undivided unit with no potential for separate ownership.

5.2 Authority to Uncover, Use or Alter System. No Person who is not authorized by the District shall uncover, make any connection with or opening into, use, alter or disturb any of the District Facilities without first obtaining written authorization from the District. Authorized persons include the District's maintenance Contractor, Engineer and licensed Contractors with written authorization.

5.3 Inclusions of Property into District Boundaries. If a Developer, Owner or Customer desires to include property lying outside the District's boundaries into the District's boundaries, a petition for inclusion shall be made pursuant to Colorado law in a form acceptable to the District, and shall be accompanied by payment of a deposit, in an amount to be determined by the District from time to time, which shall be based upon the District's estimate of the all legal, engineering and administrative fees and costs associated with the proposed inclusions and used by the District to

cover such costs. The petitioner may also be subject to a fee for the inclusion of property into the District's boundaries as determined by the Board in its sole discretion.

5.4 Extraterritorial Service. The District shall have no obligation to provide Service outside its boundaries. Service within the District is governed by the Master Meter Contract between the District and Denver Water and by the Special Connectors Agreement between the District and Metro. Boundary changes are subject to approval by Denver Water and Metro. No Service shall be provided to property outside of the District except by a written agreement of the District, and then only to the extent permitted by contract with Denver Water or Metro, as applicable. Any such written agreement with the District will establish fees, rates or charges for furnishing Service, which fees, rates or charges shall be not less than the fees, rates or charges for furnishing Service to in-District property and may be more. Any System extensions necessary to Service property outside of the District shall comply with the provisions of these Rules and Regulations.

5.5 Requirements for New Service. New Local Facilities (including Water Main or Sewer Main extensions) may not be approved and new customers may not be added, unless the District has established that there is adequate capacity in existing Water Mains or Sewer Mains and District Facilities to handle the proposed expansion and new customers. When sewer collection mains are identified to be at flow depth during peak flow of 70% of the internal pipe diameter (i.e., $d/D = 0.70$, ratio flow depth to internal pipe diameter), the District shall initiate further study and determine the best mechanism to alleviate the 0.7 d/D exceedance, where d = flow depth, D = pipe ID. All Local Facilities (including Water Mains and Sewer Mains) shall be constructed at projected ultimate capacity requirements assuming full development of all naturally tributary or non-tributary land at the densities reasonably expected under zoning in effect at the time of construction. If the District determines that existing capacity in the Water Mains or Sewer Mains and District Facilities is inadequate, then the District may plan and implement improvement programs as necessary to provide the required capacity increases. In this case, funds for such capacity increase projects will be derived from one of the following alternate sources:

5.5.1 If the property zoning has not changed since the existing Water Mains or Sewer Mains and District Facilities were planned (so that no increased loads are expected due to the subject development), the District may provide funds for the cost associated with the increased capacity.

5.5.2 If the subject property has been rezoned, and the new zoning permits a new use which would generate greater capacity than originally planned, the Developer shall be responsible for the cost associated with the increased capacity. If development is proposed upstream of the collection line segments in concern, and an improvement is determined to be required, the developer will be required to participate in a cost-sharing agreement for the determined improvement.

5.6 Requirements for Service. In addition to any other requirements for Service set forth in these Rules and Regulations, Denver Rules or the Metro Rules, the requirements set forth in this Section shall be met prior to receiving Service from the District. Acceptance of Service by any Developer, Owner or Customer shall constitute such Developer, Owner or Customer's agreement to be bound by the terms of these Rules and Regulations. Application for Water Service and any conditions of such Service are governed by these Rules and Regulations and the Denver Rules. Application for

Sewer Service and any conditions of such Service are governed by these Rules and Regulations and the Metro Rules.

5.6.1 Conditions of Service.

5.6.1.1 Construction, Extension and Oversizing of Facility/Main for Service. As a condition of receiving Service, the Developer, Owner or Customer may be required to construct, extend or enlarge Local Facilities (including Water Mains or Sewer Mains) or other facilities in order to serve the Developer, Owner or Customer's particular property or properties now and in the future.

5.6.1.2 Construction, Extension and Oversizing of Facility/Main for Future Development. As a condition of receiving Service, the Developer, Owner or Customer may be required, in the District's sole discretion, to construct Local Facilities (including Water Mains and Sewer Mains) or other facilities beyond the capacity required to serve a particular property or properties or extend such Local Facilities, Water Mains and Sewer Mains or facilities beyond the location required to serve the Developer, Owner or Customer's particular property or properties in order to effectively provide Service to additional properties within the District's Service Area at a later date. Examples of when such construction, extension or enlargement of Local Facilities, Water Mains and Sewer Mains or other facilities include, but are not limited to, the following:

5.6.1.2.1 Adjacent Developments. When a Developer is required to install Water Mains, Sewer Mains or both on a street or easement bordering or within the development so that future development can directly obtain Service through the same Mains.

5.6.1.2.2 Connecting Mains. When a proposed development is not contiguous to existing development that receives Service from the District, the District shall require the Developer to construct any intervening connecting Mains. In this case, the District may set an amount for maximum rebate, being the approved Actual Cost of the intervening connecting Mains. This rebate amount may be assigned to Owners of the intervening property if, in the opinion of the District, the intervening Owners can make reasonable use of the Mains in the future. Future Developers, Owners or Customers in the intervening area shall be required to rebate the Actual Cost, or a prorated portion thereof, before connecting other mains or lines to the subject line.

5.6.1.2.3 Benefitted Property. When a Developer is required to construct Water Mains, Sewer Mains or facilities which will benefit other property, the District shall determine the maximum rebate to be obtained from the benefitted property prior to construction. The rebate amount will be assigned to the Owners of the benefitted property, and the District shall require the Owners or future

Developers of the benefitted property to pay their pro rata share of the rebate before connecting to the Water Mains or Sewer Mains.

5.6.1.2.4 Oversize. Where the District requires that Water Mains, Sewer Mains or facilities be oversized for future users, the District may require the Owner, Developer or Customer to pay for the cost of such oversizing, in which case the Oversize Costs will be subject to cost recovery by the Owner, Developer or Customer as set forth in an agreement with the District.

5.6.1.3 Removed as of 11/14/2023

5.6.1.4 Conveyance of Property Rights. As a condition of receiving Service, the Developer, Owner or Customer shall be required, in the District's sole discretion, to convey at no charge rights-of-way, parcels, easements or other property interests to the District or other governmental entities in order to ensure that the District can provide Service.

5.6.1.5 Reimbursement for Condemnation. The District, Denver Water and Metro may require a Developer, Owner or Customer to reimburse the District, Denver Water and Metro for costs of condemnation, including but not limited to legal, engineering and administrative fees, if in the District's, Denver Water's or Metro's sole discretion it needs to condemn an easement over the property applying for Service.

5.6.1.6 Development Agreement. As a condition of receiving Service, the Developer, Owner or Customer may be required, in the District's sole discretion, to enter into a development agreement or other agreement with the District.

5.6.2 Denial or Revocation of Application. The District reserves the exclusive right to deny an application for Service when, in the opinion of the District, the Service applied for would create an excessive seasonal, or other, demand on the District Facilities, or is otherwise not in the best interests of the District. Denial may also be based upon an unresolved obligation between the District and the Applicant, inadequate documentation of rights-of-way, parcels, easements or other property interests for facilities that serve the property or any other reason as determined by the District. The District reserves the right to revoke Service for any violation of these Rules and Regulations.

5.6.3 Approval of Application/Tap Permit. The District's approval of an application for Service may be in the form of a Will Serve Letter or other written instrument. Upon payment to the District of the applicable System Development Fees and all other applicable fees by the Developer, Owner or Customer, the District shall issue a Tap Permit. The fees are subject to change at any time prior to the issuance of the Tap Permit.

5.6.4 Will Serve Letters: At the sole discretion of the Board, a Will Serve Letter may be issued by the District outlining the conditions of water and sewer service to a particular parcel. The Will Serve letter is conditional based upon requirements set forth by the District,

including having capacity to service the project. Developer, Owner or Customer may be required to pay for a capacity study, which does not guarantee that there will be any commitment from the District to provide the service. Issuance of the Will Server Letter DOES NOT constitute a contract in any form. The Will Serve Letter is merely a placeholder for future potential capacity.

5.6.4.1 Application: A Developer, and/or owner must submit an Application for Will Serve letter, and pay all associated fees (separate from the System Development and/or the Tap Fees), such application shall contain engineering designs showing calculated desired capacity for each project; such designs shall be developed by, and solely paid for by, the Developer, and/or Owner. The designs shall be done by an Engineer not affiliated with the District. The designs will then be reviewed by the District's Engineer. Such review shall be paid for by the Developer and/or Owner. Before proceeding further, any and all changes requested by the District in the designs shall be implemented. Any material modifications to the project design after approval will place the Will Serve letter in to suspension, and may be voided, upon further action of the Board. Material changes include, but are not limited to, altering the number of units to be served, type of effluence, etc.

5.6.4.2 Reserved Capacity: Upon issuance of a Will Serve letter, and at the sole discretion of the District, the District will hold the requested capacity, if such exists, in reserve for a period not to exceed 24 months from the date of the letter. If the Will Serve letter lapses past that period, new capacity studies as well as other requirements at the sole discretion of the District may need to be conducted to determine if the Will Serve letter will be re-issued.

5.6.4.3 Outstanding Will Serve Letters: Will Serve letters dated prior to September 1, 2020 shall expire December 31, 2020. Expired Will Serve Letters are subject to reapplication.

5.6.4.4 Term: Will Serve letters dated after September 1, 2020 will expire after a period of 24 months from the date of the letter.

5.6.4.5 Limitations:

- Will Serve letters DO NOT constitute substitutes for Tap Permits and/or Applications, which may be applied for when connections to the system are imminent.
- All Applications for Service shall follow these Rules and Regulations at the time of Application, including Rules and Regulations in Section 4.2, 5.1, 5.5, and
- All System Development Fees and/or Tap Fees (and other fees) applicable to the Developer, Owner or Customer will be paid for at time of application for a Tap Permit, at the rates in place at time of Permit Application date.
- Will Serve letters are applicable only to property described in the Will Serve Letter, and the addressed Developer or Owner, and are non-transferable. Change in ownership automatically voids the Will

Serve letter and the new owner shall re-initiate the process to receive a new Will Server letter.

- Will Serve letters are subject to the District Board approval, which may be subject to vote only after public notice has been posted to the District website 30 days in advance of the vote.
- Issuance of a Will Serve letter will not imply consent by third parties, including, but not limited to, Denver Water, Metro Wastewater, and Bear Creek Water District, to agree to connections and/or services.

5.6.4.6 Denial or Revocation of Application. The District reserves the exclusive right to revoke or deny an application for Will Serve Letter under the same conditions as Denial of Service per section 5.6.2 of the GMWSD Rules and Regulations.

5.7 Change to Property, Buildings, Use of Property, Equipment or Service.

5.7.1 Moved, Demolished or Destroyed Buildings. When buildings are moved, demolished or destroyed or Taps are otherwise abandoned or disconnected, the Customer, Owner or Developer must physically disconnect its Service Lines from the District's Mains pursuant to these Rules and Regulations. Reconnection shall be made solely pursuant to these Rules and Regulations. If the number of EQR's of a Tap are the same upon reconnection to the District's Mains as they were on the date the building was moved, demolished or destroyed, no additional System Development Fee will be required; however, all applicable fees, including any fees imposed by the District for inspection of the Tap upon reconnection shall still be due. If the number of EQR's of a Tap increases upon reconnection, the Customer, Owner or Developer shall be required to pay the difference between the then-current System Development Fee for the number of EQR's which were disconnected and the number of EQR's for the Service Lines that are reconnected. A Customer, Owner or Developer can reconnect to the District's Main pending submittal of a new application for Service within a period of five (5) years from the date a building is moved, demolished or destroyed. After five (5) years, the Customer, Owner or Developer must submit a new application for Service and pay the applicable fees as described in these Rules and Regulations.

5.7.2 Change to Use of Property, Equipment or Service. Any Person who causes new or increased Service shall be required to take such action as required by these Rules and Regulations, Denver Rules and Metro Rules. Any Developer, Owner or Customer shall file an amended application for Service with the District and Metro prior to making a change in Service. No change in the Customer's, Owner's or Developer's equipment, Service or use of property served shall be made without prior notice to and approval by the District, Denver Water and Metro, as applicable. If any such change will, in the opinion of the District, Denver Water or Metro, increase the burden placed on the District's, Denver Water's or Metro's respective systems by the Customer, Owner or Developer, the District, Denver Water or Metro shall determine the fees, rates or charges for furnishing Service and whether an increased Tap is required and require a payment by the Customer, Owner or

Developer of any additional fees, rates or charges and any costs resulting from such determination. If the District determines that the change requires payment of fees, rates, charges or costs in excess of those currently paid on the property, such amounts shall be paid to the District before the change occurs. No such determination shall result in a refund or credit of any kind to the Customer, Owner or Developer. The District may also require, at the Developer, Owner or Customer's sole expense, physical changes in the facilities through which the Service connects to the property in order to accommodate Developer, Owner or Customer's proposed change. The Developer, Owner or Customer shall not change the grade over District Facilities or District property without prior written approval from the District, which may be granted or withheld in the sole discretion of the District. Any violation of these provisions may result in the assessment of additional fees, rates, tolls, charges and penalties or revocation of Service as provided in Articles 8 and 9 of these Rules and Regulations.

5.8 Prohibited Acts.

- 5.8.1 Unauthorized Persons.** No unauthorized Person or entity shall connect to or disconnect from, cover, uncover, use, alter, disturb, make any opening onto, alter, disturb or open District Facilities without first obtaining a written authorization from the District. Unauthorized activities with respect to the District's Facilities include, but are not limited to, unauthorized connections to the System, even though such acts may be performed on a privately owned or maintained Service Line.
- 5.8.2 Unauthorized Connection to System.** No unauthorized Person shall be allowed to connect to or disconnect from the District's Water System or Sewer System or to enlarge or otherwise add to or change equipment, Service or use of property without prior written approval of the District, Denver Water and Metro, as applicable. All requests for a connection/reconnection of Service may be granted or denied by the District at its sole discretion. All connections/reconnections of Service from the District shall be inspected and approved only by District personnel, regardless of the circumstances concerning the connection/reconnection. A connection and a reconnection are each a separate, distinct function and shall require additional inspections by District personnel. The District may assess applicable fees, rates, tolls, charges and penalties as specified in Article 8 of these Rules and Regulations. No Person shall be allowed to connect to the Water System or increase Water Service therefrom except as permitted by the Denver Rules and with such approvals as are required by Denver Water. No Person shall be allowed to connect to the Sewer System except as permitted by the Metro Rules and with such approvals as are required by Metro. Upon the discovery of any unauthorized connections, including but not limited to bypass of a meter during construction or otherwise, the Developer, Customer or Owner may be subject to the violation provisions of these Rules and Regulations.
- 5.8.3 Prohibited Use of System.** Prohibited uses of the System includes, but is not limited to, an unauthorized draw from or discharge into the System, an unauthorized connection or disconnection of Service Lines, tampering with or in any way modifying any part of the District Facilities or modifying Service Lines in any way that violates these Rules or Regulations.

5.8.4 Illegal Acts. No Person shall maliciously, willfully or negligently, break, damage, destroy, cover, uncover, deface, tamper or refuse “right of entry,” as specified in Section 4.8 of these Rules and Regulations, to any portion of the System even though all or portions of the same may be privately owned and maintained by the Developer, Owner or Customer. No Person shall install or use any type of septic system or drill or install any water well facility or system within the District’s Service Area, unless authorized by the District in writing or by these Rules and Regulations. No Person shall violate any provisions of these Rules and Regulations. The District may pursue recovery to the limits of local, state and federal laws from any Person(s) that cause damage to the System.

5.9 Forfeitures.

5.9.1 Revocation of Service. Service shall be revocable by the District for non-payment of any fees or charges owing to the District or violation of any provision of these Rules and Regulations or the conditions or obligations set forth in any Tap Permit or agreement as provided in these Rules and Regulations. Water Service may be revoked by Denver Water pursuant to the Denver Rules. Sewer Service may be revoked by Metro pursuant to the Metro Rules.

5.9.2 Failure to Connect. A Developer, Owner or Customer’s right to connect to the System shall terminate and any System Development Fees paid shall be forfeited if the Tap is not connected to the District’s Facilities within twenty-four (24) months of the payment of the System Development Fees unless the Developer, Owner or Customer has entered into an agreement with the District that specifically addresses the timing of Connection for pre-paid Taps.

5.9.3 Revocation of Tap Rights. A Tap Permit shall be revocable by the District for violation of any provision of these Rules and Regulations or the conditions or obligations set forth in any Tap Permit or agreement as provided in Section 9.2.2.7 of these Rules and Regulations. If the right to connect to the Water System or Sewer System is revoked, the Customer, Owner or Developer may reacquire such Tap rights only by reapplying for a Tap and after paying all fees due and owing the District, according to the then-current fee schedule.

5.10 Non-Transferability of Taps and Tap Permits. Tap Permits or paid Taps only attach to the property identified in the Tap Permit. They are not affected by changes in the ownership of the property and are usable only in accordance with the terms of the Tap Permit. Tap Permits or paid Taps are not transferable to other properties nor may fees be transferred from one property to any other property without the written consent of the District, Metro and Denver Water, as applicable.

5.11 Limitation on Assignment. No Taps purchased from the District may be sold or assigned without the express written consent of the District, Metro and Denver Water, as applicable, and subject to such terms and conditions as the District, Metro and Denver Water may impose.

5.12 Penalties. Any Person that violates any of the provisions of these Rules and Regulations or the conditions or obligations set forth in any Tap Permit or agreement may be subject to the enforcement provisions and penalties set forth in Article 9 of these Rules and Regulations.

5.13 Reimbursement of District Costs. Any Person that violates any of the provisions of these Rules and Regulations or the conditions or obligations set forth in any Tap Permit or agreement shall become liable for reimbursement of any District costs associated therewith, including but not limited to legal, engineering and administrative fees associated therewith.

ARTICLE 6 – USE OF THE SEWER SYSTEM

- 6.1 Authority to Uncover, Use or Alter Sewer System.** No Person who is not authorized by the District shall uncover, make any connection with or opening into, use, alter or disturb any Sewer Main or appurtenance without first obtaining written authorization from the District. Authorized persons include the District's maintenance Contractor, Engineer and licensed Contractors with written authorization.
- 6.2 Responsibilities of the Owner.** Each Owner shall be responsible for maintaining the entire length of the Sewer Service Line, including appurtenances, serving the property from the structure to the District's manhole or Sewer Main including the Sewer Main Tap. Leaks, stoppage or breaks in the Sewer Service Line will be repaired by the Owner within a reasonable period of time after notification of such condition by the District or upon discovery of the condition by the Owner. If progress satisfactory to the District toward repairing said leak, stoppage or break has not been completed within such time period, the District shall have the express right to enter onto the Owner's property, effect the repair, collect costs, including but not limited to legal, engineering and administrative fees, from the Owner and place a lien against the property of such Owner to secure payment of such costs. Permission to enter onto the property and effect repairs and agreement to reimburse the District for costs is expressly given in partial consideration for the provision of Sewer Service by the District. The District will provide notice to an Owner prior to entering private property where such notice is possible and reasonable in the District's sole discretion.
- 6.3 Prohibited Acts.** No Person shall discharge, or cause to be discharged, any storm water, surface water, groundwater, roof runoff, sub-surface drainage, cooling water, Sump Pumps or untreated industrial process waters to the Sewer System. No public or private swimming pool shall be connected to the Sewer System without first obtaining a special permit therefor from the District, which permit shall define and specify the hour or hours during which water may be discharged from such pools into the Sewer System and prescribe the fees and charges therefor including legal, engineering and administrative fees, if any. The Special Permit Application is available at the District office. A Special Permit will only be issued by the District after receipt by the District of a completed Special Permit Application, all applicable fees and all other required documentation. **The terms, conditions and requirements of the Special Permit Application are applicable to all work and are incorporated into these Rules and Regulations.**

Except as hereinafter provided, no Person shall discharge, or cause to be discharged, to any Sewer Main any Special Sewage or Prohibited Sewage or any harmful waters or wastes, whether liquid, solid or gas, capable of causing obstruction to the flow in sewers or damage or hazard to structures, maintenance personnel or other interference with the proper operation of the Sewer System. In particular, no Person shall discharge grease into the Sewer System which may cause an obstruction or other interference to the flow in the sewer. The use of grease traps may be required as provided in Section 6.6.2 of these Rules and Regulations.

No Person shall maliciously, willfully or negligently break, damage, destroy, uncover, deface or tamper with any portion of the Sewer System.

- 6.3.1 Surface Water Runoff and Groundwater.** No roof downspout, exterior foundation drains, perimeter drains, area drains, Sump Pumps or other sources of surface runoff or

groundwater shall be connected to or allowed to discharge into the Sewer System, directly or indirectly, or with a Sewer Service Line for the purpose of draining ground or surface waters into the Sewer System. No physical Connections shall be permitted whereby a Sewer Service Line is connected to a Sump Pump or other facility in such a manner that through the manipulation of valves or because of lack of back pressure valves, or because of any other arrangement, it is possible to drain flood, overflow, drain, storm or groundwater directly or indirectly into the Sewer System of the District. Examination for the possibility of infiltration of groundwater through a floor drain shall be made by the District's maintenance Contractor or Engineer, either or both of whom shall have the right to enter upon any property at any reasonable time for the purpose of making such an inspection. If it is found that such infiltration is occurring, the District shall give written notice to the Owner or Customer requiring the disconnection of such drain from the Sewer Service Line or Sewer System within five (5) days, otherwise the disconnection will be made by the District and the expense thereof paid for by the Owner or Customer as provided by law.

6.3.2 Cesspools and Septic Tanks. No Connection to the Sewer System will be permitted when the Sewer Service Line extends through or from a cesspool or septic tank.

6.3.3 Industrial Waste. There shall be no Industrial Waste discharged into the Sewer System or any individual sewer system, septic tank or leach field without compliance with all applicable laws or rules and regulations governing discharge of Industrial Waste. No manufacturing, processing or industrial plant shall discharge its wastes or any pollutant into the Sewer System without first receiving a written authorization from the District to do so.

6.3.4 Other Wastes. Bakery/restaurant wastes, car washing wastes, swimming pool drainage and floor drainage from enclosed and covered areas may be connected to the Sewer System only by special permit from the District and may require pretreatment or installation of interceptors as provided in Section 6.6 of these Rules and Regulations. The Special Permit Application is available at the District office. A Special Permit will only be issued by the District after receipt by the District of a completed Special Permit Application, all applicable fees and all other required documentation. **The terms, conditions and requirements of the Special Permit Application are applicable to all work and are incorporated into these Rules and Regulations.**

6.4 Classification of Wastes. It shall be the policy of the District to classify wastes into three (3) main categories termed Normal Sewage, Special Sewage or Prohibited Sewage, as defined in Article 1 of these Rules and Regulations. The classification of wastes shall be the responsibility of the Engineer and shall follow the recommended procedures of the Colorado Department of Public Health and Environment, including but not limited to 5 CCR 1002-63, Metro, including but not limited to the Metro Rules, and federal regulations, including but not limited to the Federal Water Pollution Control Act as amended by the Clean Water Act of 1972 and specifically Part 403 of the Code of Federal Regulations and, subject to concurrence by the Board, shall be final and binding. Testing and analysis shall be accomplished by Metro for the purpose of establishing Sewage treatment charges as set forth in the Metro Rules.

6.5 Discharge of Special Sewage.

6.5.1 Approval Required. The admission into the Sewer System of any Special Sewage shall be subject to the review and approval of the Board, which may prescribe limits on the strength and character of such Special Sewage. Where necessary, in the opinion of the Board, the Customer shall provide, at the Customer's expense, such pretreatment facilities as may be necessary to treat such Special Sewage prior to discharge to the Sewer Main. Moreover, such Special Sewage may be subject to regulations regarding required pretreatment for certain industrial Customers. Plans, specifications and any other pertinent information relating to proposed pretreatment facilities shall be submitted for the approval of the District, the Colorado Department of Public Health and Environment and Metro; no construction of such facilities shall be commenced until such approval is obtained in writing. Where pretreatment facilities are provided for any Special Sewage, they shall be maintained continuously in satisfactory and effective operation, at the sole discretion of the District, by the Customer, at the Customer's own expense.

6.5.2 Surcharge. The District may charge Customers a surcharge for Special Sewage exceeding the following concentrations:

B.O.D.	=	300 mg/l
Suspended Solids (SS)	=	300 mg/l
TKN	=	60 mg/l

Such surcharge may include any additional charges the District is assessed by Metro as a result of the Special Sewage exceeding the foregoing concentrations.

6.5.3 Monitoring Manhole or Vault Requirement. When required by the District, any Customer served by a Sewer Service Line carrying Special Sewage shall install and maintain, at the Customer's expense, a suitable monitoring manhole or vault in the Sewer Service Line to facilitate observation, Sampling and measurement of the wastes. The manhole/vault shall be installed and maintained by the Customer at the Customer's own expense. All measurements, tests and analysis of the characteristics of waters and wastes shall be determined in accordance with "Standard Methods for the Examination of Water and Wastewater," latest edition, a joint publication of the American Public Health Association, the American Water Works Association and the Water Pollution Control Federation, and shall be determined at the control manhole, or upon suitable samples taken at said control manhole. Compliance shall be made with any and all applicable requirements contained in the most recent OSHA "Confined Space Regulations," including any necessary and applicable permits to enter the manhole. In the event that no special manhole or vault has been required, the monitoring manhole shall be considered to be the nearest down-stream manhole in the Sewer Main to the point at which the Sewer Service Line is connected.

6.6 Pretreatment and Interceptor Requirements.

6.6.1 Pretreatment: General Requirements. Where the District determines it necessary, which determinations shall be final, the Owner shall provide, at the Owner's expense, such preliminary treatment as may be necessary. Where preliminary treatment facilities are provided for any Sewage, the District may require the Owner to acquire District approval as to the adequacy of the design of preliminary treatment facilities, and once built, the facilities shall be maintained continuously in satisfactory and effective operation by the Owner. When required by the District, the Owner of any property served by a Sewer Service Line carrying Industrial Waste shall install a suitable monitoring manhole, vault or monitoring point in the Service Line to facilitate observation, Sampling and measurement of the wastes. Such manhole, vault or monitoring point shall be installed by the Customer at the Customer's expense; it shall also be maintained at the Customer's expense.

In addition to the foregoing requirements, the Customer shall also comply with the Rules and Regulations of Metro regarding discharge prohibitions and regulations.

The District has assigned the monitoring, Sampling and reporting of non-domestic strength Sewage to Metro. Metro may directly assess penalties to non-conforming contributors in accordance with the Clean Water Act.

6.6.2 Requirement for Grease and Sand/Oil Interceptors. In accordance with the GREASE INTERCEPTOR AND SAND/OIL INTERCEPTOR DESIGN CRITERIA, as the same may be amended from time to time, which are available upon request from the District, interceptors (including but not limited to grease and sand/oil interceptors) shall be provided for the proper handling of liquid wastes containing grease or sand/oil in excessive amounts, any flammable wastes, sand, solids, acid or alkaline substances or other constituents harmful to the System or which detrimentally affect the Sewage treatment process. In addition to the circumstances set forth herein, interceptors shall be provided when, in the opinion of the District, they are necessary. All costs associated with interceptors are the sole cost and expense of the Developer, Customer or Owner. Grease and sand/oil interceptors shall be in an accessible location for maintenance and inspection and shall be constructed of impervious materials capable of withstanding abrupt and extreme changes in temperature. They shall be watertight, and, if necessary, gastight and vented. Where installed, all grease and sand/oil interceptors shall be maintained by the Customer at the Customer's expense in continually efficient operation at all times. The District requires cleaning and pumping of any interceptors on a minimum quarterly basis or more frequently as required by the District. Unless such requirements are met, a monthly premium sewer charge of \$250.00 may be assessed. For new grease and sand/oil interceptors, supporting design criteria and detailed drawings, as needed for review and approval by the District, shall be submitted. The minimum interceptor capacity shall be 750 gallons.

6.6.3 District Approval. Interceptor plans shall be submitted to the District Manager, who will assign an Engineer, who must approve them prior to installation. The cost of reviewing and approving such plans and inspection and approval of the installation shall be charged to the Applicant.

6.6.4 Inspection and Enforcement of Sewage Discharge Regulations.

6.6.4.1 Periodic Inspections and Fees. Periodic maintenance reviews or inspections may be performed by the District to ensure compliance with these Rules and Regulations. The District may charge a fee for such inspections, which the District at its option may bill directly to the Developer, Owner or Customer.

6.6.4.2 Authorization to Enter Upon Private Property. As partial consideration for the provision of Sewer Service, the Developer, Owner or Customer grants the District the express right to enter upon private property for the purposes of such inspection and for any necessary maintenance of District Facilities, including interceptors. The District will provide notice to an Owner prior to entering private property where such notice is possible and reasonable in the District's sole discretion.

6.6.4.3 Unauthorized Discharge of Sewage. Discharge of Sewage in any manner not permitted by these Rules and Regulations is hereby declared a public nuisance and may be corrected or abated as directed by the District at the cost of the violator.

6.7 Compliance with Other Applicable Regulations. Developers, Owners and Customers shall comply with any applicable rules or regulations established by any local, state or federal agency, in particular, by Metro. No Developers, Owners or Customers shall discharge any pollutant in violation of any applicable regulation, including maximum pollutant levels, established by any local, state or federal agency, including but not limited to Metro, the Colorado Department of Public Health and Environment, the Water Quality Control Commission and the Environmental Protection Agency. Each Developer, Owner and Customer shall comply with any prohibitions imposed on the District with regard to discharge of pollutants. If, as a result of any such violation, the District is subject to any civil or criminal liability, any fines, fees or penalties or other costs assessed against the District, and any costs incurred by the District to defend against such liability, including but not limited to legal, engineering and administrative fees, shall be charged against the violator by the District.

ARTICLE 7 – USE OF THE WATER SYSTEM

- 7.1 Authority to Uncover, Use or Alter Water System.** No Person who is not authorized by the District shall uncover, make any connection with or opening into, use, alter or disturb any Water Main or appurtenance without first obtaining written authorization from the District. Authorized persons include the District’s maintenance Contractor, Engineer and licensed Contractors with written authorization.
- 7.2 Responsibilities of the Owner.** Each Owner shall be responsible for maintaining the entire length of the Water Service Line, including appurtenances, serving the property from the structure to the District’s Water Main including the Water Main Tap. Leaks, stoppage or breaks in the Water Service Line will be repaired by the Owner within a reasonable period of time after notification of such condition by the District or upon discovery of the condition by the Owner. If progress satisfactory to the District toward repairing said leak, stoppage or break has not been completed within such time period, the District shall have the express right to enter onto the Owner’s property, effect the repair, collect costs, including but not limited to legal, engineering and administrative fees, from the Owner and place a lien against the property of such Owner to secure payment of such costs. Permission to enter onto the property and effect repairs and agreement to reimburse the District for costs is expressly given in partial consideration for the provision of Water Service by the District. The District will provide notice to an Owner prior to entering private property where such notice is possible and reasonable in the District’s sole discretion.
- 7.3 Provision of Service.** Water Service is provided within the District’s Service Area pursuant to the Master Meter Contract with Denver Water.
- 7.4 General.** The District’s Water System has been planned and constructed to provide water for conventional, domestic, irrigation, industrial and commercial uses and fire protection. Persons wanting to use the Water System for an industrial or commercial water supply, which could be expected to require large quantities of water or unusual demand rates, shall be required to submit demand data as to water use before a Tap Permit will be issued; said Tap Permit may contain use limitations as determined necessary by the District.
- 7.5 Cross-Connection/Dual Supply.** Water from the District’s Water System and water from any other source shall be distributed through systems entirely independent of each other and Cross-Connection between such supplies is prohibited. Where a potential of backflow is present, a protective device or system acceptable to the District shall be installed to prevent its occurrence. All automatic lawn sprinkler systems shall be equipped with an approved backflow device, as specified in the District’s CROSS-CONNECTION CONTROL AND BACK FLOW PREVENTION REGULATIONS, as the same may be amended from time to time, which are available upon request from the District.

All plumbing installations shall be designed and installed in conformity with the latest edition of the Colorado Department of Public Health and Environment’s Backflow Prevention and Cross-Connection Control Rule.

The Customer, Owner or Developer shall install, operate, test and maintain the backflow device as required by the District’s CROSS-CONNECTION CONTROL AND BACK FLOW PREVENTION

REGULATIONS. **Tests shall be made on the device at least once per year or as determined by the District** in accordance with the District's CROSS-CONNECTION CONTROL AND BACK FLOW PREVENTION REGULATIONS.

7.6 Fire Protection Sprinkler System. All fire sprinkler systems shall meet the then-current National Fire Protection Association requirements and additionally shall meet the requirements of applicable local, state and federal building and fire protection codes. The District assumes no obligation to provide or liability related to adequacy of water pressure or quantity for fire protection water sprinkler systems.

7.7 Compliance with Other Applicable Regulations. Developers, Owners and Customers shall comply with any applicable rules or regulations established by any local, state or federal agency, in particular, by Denver Water. If, as a result of any violation of such rules and regulations, the District is subject to any civil or criminal liability, any fines, fees, penalties or other costs assessed against the District, and any costs incurred by the District to defend against such liability, shall be charged against the violator by the District.

ARTICLE 8 – FEES, RATES AND CHARGES

- 8.1 General.** The Board is empowered to fix and from time to time to increase or decrease fees, rates, tolls, penalties or charges for services, programs or facilities furnished by the District pursuant to Sections 32-1-1001(1)(j)(l) and 32-1-1006(1)(g), Colorado Revised Statutes, as amended from time to time. The District imposes and collects such fees, rates, tolls and charges in amounts to ensure they are sufficient to operate, maintain and provide the Services and the District Facilities. The District imposes and utilizes its fees, rates, tolls and charges in accordance with applicable law for protection of the health and welfare of residents and property owners of the District.
- 8.2 Application of this Article.** The fees, rates, tolls, charges and penalties established by the District herein shall in no way obligate the District with respect to the provision of Service outside of the boundaries of the District.
- 8.3 Schedule of Fees, Rates and Charges.** The fees, rates, tolls, charges and penalties in existence and in effect are based on the costs of serving existing customers and are set forth in the SCHEDULE OF FEES, RATES AND CHARGES, as the same may be amended from time to time. Such fees, rates, tolls, charges and penalties shall remain in effect until modified by the Board in accordance with these Rules and Regulations and applicable laws. Nothing contained herein shall limit the Board from modifying fees, rates, tolls, charges and penalties or from modifying any classification. Revised fees, rates, tolls, charges and penalties adopted by the District will become a part of these Rules and Regulations and will be attached hereto as Appendix A after any such adoption.
- 8.3.1 Water Surcharge.** If the District determines that costs, in addition to the costs for serving existing customers, would be associated with providing Water Service to all or any portion of property included within the District boundaries, it reserves the right to add a surcharge for Water Service to the property to which such additional costs apply, based on the actual additional costs. The area(s) to which the surcharge applies shall be clearly identified, and the surcharge equitably allocated.
- 8.3.2 Sewer Surcharge.** If the District determines that costs, in addition to the costs for serving existing customers, would be associated with providing Sewer Service to all or any portion of property included within the District boundaries, it reserves the right to add a surcharge for Sewer Service to the property to which such additional costs apply, based on the actual additional costs. The area(s) to which the surcharge applies shall be clearly identified, and the surcharge equitably allocated.
- 8.4 Adjustment of Fees, Rates and Charges.** In those situations where, in the District's sole discretion, the fees, rates, tolls, charges and penalties shown on the SCHEDULE OF FEES, RATES AND CHARGES and EQUIVALENT RESIDENTIAL UNIT SCHEDULE, as the same may be amended from time to time, do not represent a fair, reasonable and equitable charge for the intended use, the District, in its sole discretion, may adjust said fees, rates, tolls, charges and penalties.
- 8.5 Rebate Agreements/Fees.** In circumstances where a Developer is required to construct, extend or enlarge Water Mains, Sewer Mains or facilities beyond the location required to serve the Developer, Owner or Customer's particular property or properties in order to effectively provide

Service to additional properties within the District's Service Area at a later date as described in Section 5.6.1.2 of these Rules and Regulations, the District may, in its sole discretion, enter into an agreement with the Developer, Owner or Customer as described in Section 5.6.1.3 of these Rules and Regulations.

8.6 Payment of Fees, Rates and Charges.

8.6.1 Accounting Adjustments. In the District's sole determination, accounts may be adjusted when evidence is presented clearly establishing that an error was made in billing the account, crediting payments or calculating charges for a period not to exceed twelve (12) months. Upon any such District determination, adjustments will be credited/debited to the Customer's account.

8.6.2 Meter Adjustments. In the District's sole determination, billing charges on accounts of metered Service may be adjusted when necessary and to the extent required to correct errors if there is an error that is no fault on the part of the Developer, Owner or Customer of metered property.

8.6.2.1 Meter Testing. If a meter has become inaccurate, Water Service may be charged on an estimated consumption rate based upon previous consumption for the period during which it appears such inaccuracy continued. The District may remove and test a meter upon the request of the Developer, Owner or Customer or if it is suspected by the District that the meter in question has become inaccurate. A meter removed and tested at the request of the Developer, Owner or Customer of the property and found to be accurate shall subject the Developer, Owner or Customer to charges covering such costs as are reasonably incurred by the District.

8.6.2.2 Remote Meter Failure. If a remote meter reading device has been installed at the property and a difference in readings occurs between the remote reading device and the water meter installed inside the property, billing charges shall be derived from the water meter reading from the water meter installed within the property.

8.6.3 Construction Water Charge. Any Developer, Owner or Customer that desires to have Water Service available at a property for construction use prior to the time a meter may be properly set and protected from damage must obtain a permit or written authorization, as applicable, from the District prior to using such Water Service and may only receive such Water Service in the manner directed by the District. Any Developer, Owner or Customer that desired to have Water Service from a hydrant must submit a completed "Hydrant Permit Application" form, all applicable fees and charges, and all other required supporting documentation to the District. Payment of the construction water fees and charges will enable the property to receive Water Service for construction use until such time as a meter may be properly set and protected from damage or the District's authorization for construction Water Service has expired, whichever occurs first. Occupancy of the property shall not occur until such time as a meter may be properly set and protected from damage. The District may, in its sole discretion, refuse to allow construction Water Service prior to the time a meter is properly set and protected from

damage. Any water used at a construction site without prior authorization of the District and payment of all applicable fees and charges shall be an “unauthorized use” and is subject to all applicable penalties. The Hydrant Permit Application is available at the District office. A Hydrant Permit will only be issued by the District after receipt by the District of a completed Hydrant Permit Application, all applicable fees and all other required documentation. **The terms, conditions and requirements of the Hydrant Permit Application are applicable to all work and are incorporated into these Rules and Regulations.**

8.6.4 Unauthorized Use by District Customers. When Water Service has been shut off by the District and is subsequently turned back on by anyone other than the District, such Water Service use is unauthorized. Such an unauthorized use will result in the assessment of a shut-off fee, and Water Service will not be turned back on by the District until all outstanding charges, fees, rates and penalties are paid. The Developer, Owner or Customer will be charged additional shut-off fees and a labor charge for all work required to turn off unauthorized Water Service. Repeat offenses by the Developer, Owner or Customer may also be subject to criminal or civil liability as described in Section 9.2.

8.7 Billing. The District shall have the right to issue only one (1) billing statement for a multi-unit structure or development which is served by a single Service Line. The Owner of such property shall be responsible for all charges to the property. If the units are owned by separate parties, the parties shall designate a responsible party, association or other representative party to receive billing statements and notices from the District.

8.7.1 Rental or Leased Properties. The District will not accept name changes for the purpose of placing the name of a renter or renters on the bills for rental properties. Arrangements for the payment of bills by renters shall be the responsibility of the Owner of the property. Bills for all properties within the District will remain in the name of the current Owner of the property. With the permission of the Owner of the property, a copy of the invoice and second notice may be sent directly to the property to the attention of “Renter”, in addition to the invoice and initial notice being sent to the Owner of the property.

Any rental properties that were placed in the renters’ name prior to the imposition of the foregoing restriction that become delinquent and allow for revocation of Service to the property after any two (2) billing cycles within a one- (1) year time period will be automatically changed back into the name of the then-current Owner of the property. After the first delinquency that results in revocation of Service to the property, a letter of notice will be sent to the Owner of the property stating that upon the second delinquency on a renter’s account, the billing of the property will change back into the name of the Owner of the property and any unpaid charges including revocation of Service fees will become the Owner’s responsibility. All subsequent billings will be sent directly to the Owner of the property, and any name changes other than a name change to a new Owner of the property will be refused. Nothing in this provision shall be interpreted to allow for a renter not receiving bills in his or her name prior to the time of adoption of these Rules and Regulations to have service placed in his or her name at any time.

8.8 Due Date. The Owner or Customer shall pay to the District the full amount of each statement by the due date shown on the statement. Where the Owner or Customer believes said statement is

in error, the Owner or Customer must file within fifteen (15) days after the statement date, a written notice to the District of the presumed error and request a clarification from the District. Upon review by the District and re-submittal or revision of the statement, payment shall be due no later than fifteen (15) days from the date of the resubmitted statement. Any appeal of resubmitted statements must be made in accordance with Article 9 of these Rules and Regulations. Any unpaid amounts outstanding more than five (5) days beyond the due date may be subject to late fees as provided in Section 9.2.2.2.

8.9 Responsibility for Costs. Any Person who seeks to do business with the District, obtain agreements with the District, obtain approval of plans from the District or otherwise undertake activities which cause the District to incur costs or fees shall be responsible for paying the District for all such costs. Any activities by Persons that may require additional costs to the District, including but not limited to additional legal, engineering and administrative fees, shall pay the District for all such additional costs. Such payment shall be due at such time as the Person receives an invoice from the District or as the Board directs, but in no case later than the date when agreements are executed, approvals are delivered or such Person receives benefit from the District for such activities.

8.10 Perpetual Lien/Foreclosure. In accordance with Section 32-1-1001(1)(j)(I), Colorado Revised Statutes, as may be amended from time to time, and as more particularly discussed in Section 9.2.2.4 of these Rules and Regulations, until paid, all rates, tolls, charges, fines, fees, assessments, penalties and costs shall constitute a perpetual lien on and against the property served, and any such lien may be foreclosed in the same manner as provided by the laws of this state for the foreclosure of mechanics' liens. If at any time it becomes necessary for the District, following efforts to collect overdue payments of any fee or charge assessed by the District under these Rules and Regulations or Colorado law, to initiate foreclosure proceedings as allowed by Section 32-1-1001(1)(j), Colorado Revised Statutes, as amended, all costs so incurred by the District shall be due and payable by the Customer or Owner. Payment of all costs and fees outstanding against the subject property shall be a precondition to the resumption of Service to that property.

8.11 Penalties for Late Payment or Non-Payment. Late payment or non-payment of any rates, tolls, charges, fines, fees or assessments owed to the District may result in the District taking one or more actions, which may include, but are not limited to charging a late fee, penalty and interest or revoking Service in accordance with Article 9 of these Rules and Regulations. If Service is revoked, a shut-off fee, in the amount set forth in the SCHEDULE OF FEES, RATES AND CHARGES, as the same may be amended from time to time, will be assessed to the Customer. Service to the property will not be reconnected until the Customer has paid the shut-off fee plus any outstanding past due charges. Further, the District has the right to assess to any Customer who is overdue in payment of his or her account, all legal, court and other costs necessary to or incidental to the collection of said account.

ARTICLE 9 – ENFORCEMENT, VIOLATIONS AND PENALTIES

9.1 Violations. Any intentional or negligent action taken by a Person in contravention of these Rules and Regulations or the conditions or obligations set forth in any Tap Permit or agreement shall be considered a violation and is subject to the provisions of this Article.

9.2 Enforcement Remedies.

9.2.1 Notification of Violation. Whenever the District finds that any Person has violated or is violating these Rules and Regulations or the conditions or obligations set forth in any Tap Permit or agreement, the District may issue a written notice to resolve the obligation and correct the problem or the practice at issue. If, in the sole discretion of the District, an Emergency exists, the District may take immediate action as provided in Section 9.4 of these Rules and Regulations and shall provide written notice as soon thereafter as possible. In the event of late payment or non-payment of any rates, tolls, charges, fines, fees or assessments, the District is not required to send any notification beyond the billing statement, unless otherwise required by law. Should the violation still exist after the time limit on the notice has elapsed, the District may revoke Service, revoke a Tap Permit or assess charges, fines and penalties as provided in Section 9.2.2 of these Rules and Regulations.

9.2.2 Penalties for Violations.

9.2.2.1 Penalty. Any Person in violation of these Rules and Regulations or the conditions or obligations set forth in any Tap Permit or agreement may be assessed penalties in an amount to be determined by the District or as shown on the SCHEDULE OF FEES, RATES AND CHARGES, as the same may be amended from time to time. Each violation may be subject to a penalty, and each day of a violation may be considered a separate violation. Penalties may be added to the Developer, Owner or Customer's next bill.

9.2.2.2 Late Fee. At any time a Developer, Owner or Customer is more than five (5) days late in payment of any rates, tolls, charges, fines, fees or assessments due the District, the District shall have the right to assess a late fee on the unpaid balance in the amount shown on the SCHEDULE OF FEES, RATES AND CHARGES, as the same may be amended from time to time.

9.2.2.3 Interest. Unpaid rates, tolls, charges, fines, fees, assessments or penalties may, after thirty (30) calendar days, be assessed interest as allowed by law.

9.2.2.4 Perpetual Lien/Foreclosure. In accordance with 32-1-1001(1)(j)(I), Colorado Revised Statutes, as may be amended from time to time, until paid all rates, tolls, charges, fines, fees, assessments, penalties and costs (including but not limited to legal, engineering and administrative fees) shall constitute a first and perpetual lien on or against the entire property served, including all units served by a common Service Line and on or against any property benefitted by a Service Line or Main line extension. Any such lien may be foreclosed in the manner provided by law.

9.2.2.5 Certification of Amount to County Treasurer. In addition to any other means provided by law, the Board may elect to have certain delinquent rates, tolls, charges, fines, fees, penalties and assessments made or levied solely for Service certified to the treasurer of the county to be collected and paid over by the treasurer of the county in the same manner as taxes in accordance with Section 32-1-1101(1)(e), Colorado Revised Statutes, as may be amended from time to time.

9.2.2.6 Revocation of Service. Should a Developer, Owner or Customer remain in violation of these Rules and Regulations or the conditions or obligations set forth in any Tap Permit or agreement after the time limit stated on either a billing statement or a violation notice issued pursuant to Section 9.2.1 of these Rules and Regulations has elapsed, the District may revoke Service. In the event of a proposed revocation of Service, the Developer, Owner or Customer shall be given not less than ten (10) days' advance notice in writing of the revocation, which notice shall set forth the following:

- a. The reason for the revocation and the date Service(s) shall be terminated; and
- b. That the Developer, Owner or Customer has the right to contact the District and the manner in which the District may be contacted for the purpose of resolving the obligations; and
- c. That there exists an opportunity for a hearing in accordance with Section 9.3 of these Rules and Regulations.

If the obligations are not resolved or a request for a hearing, accompanied by a deposit equal to the amount of any fees, rates, tolls, charges and penalties specified in the notice, is not received by the District within ten (10) days, the District may revoke the Service(s) and the Developer, Owner or Customer may be assessed the cost of the disconnection. The Developer, Owner or Customer's deposit for Service, if any, shall be applied against the outstanding obligation. If Service is revoked, a shut-off fee, in the amount set forth in the SCHEDULE OF FEES, RATES AND CHARGES, as the same may be amended from time to time, will be assessed to the Customer. Service to the property will not be reconnected until the Customer has paid the shut-off fee plus any outstanding past due charges. Further, the District has the right to assess to any Customer who is overdue in payment of his or her account, all legal, court and other costs necessary to or incidental to the collection of said account.

9.2.2.7 Revocation of Tap Permit. In addition to the other rights and remedies set forth in these Rules and Regulations, any Developer, Owner or Customer who violates these Rules and Regulations, any conditions of the Tap Permit or agreement, or violates any applicable local, state or federal regulation, is subject to having his or her Tap Permit revoked after receipt of notice of such

proposed revocation in substantially the same manner as provided in Section 9.2.1 of these Rules and Regulations. If the Tap Permit is revoked, the Developer, Owner or Customer may reacquire such Tap Permit only by reapplying for Service in accordance with the Rules and Regulations, and after paying all fees due and owing the District and the then-current System Development Fees charged by the District under these Rules and Regulations for the use in question and complying with all other applicable requirements of the District.

9.2.2.8 Civil Liability. Any Person who intentionally or negligently violates any provision of these Rules and Regulations or the conditions or obligations set forth in any Tap Permit or agreement may be subject to civil liability to the District.

9.2.2.9 Criminal Liability. Any Person who violates these Rules and Regulations or the conditions or obligations set forth in any Tap Permit or agreement and in doing so commits a misdemeanor or felony may be charged by the appropriate authority with a misdemeanor or felony, and upon conviction thereof, shall be subject to such penalties as provided by law.

9.2.2.10 Other Remedies Provided at Law. In addition to the other rights and remedies set forth in these Rules and Regulations the District may exercise any other rights or remedies it may be entitled to under law or in equity to enforce these Rules and Regulations or the conditions or obligations set forth in any Tap Permit or agreement.

9.2.2.11 Reimbursement of District Costs. Any Person who violates any of the provisions of these Rules and Regulations or the conditions or obligations set forth in any Tap Permit or agreement shall become liable to the District for any expense, loss or damage occasioned by reason of such violation, including, but not limited to legal, engineering, administrative, collection, court and accounting fees and costs.

9.3 Hearing and Appeal Procedures.

9.3.1 General. If a Developer, Owner, or Customer wishes to dispute any rates, tolls, charges, fines, fees, assessments, or penalties imposed by the District, or a determination made by the District, the Developer, Owner, or Customer may appeal such rates, tolls, charges, fines, fees, assessments, penalties, or determination by following the procedure set forth below (a Developer, Owner, or Customer filing an appeal is referred to in the remainder of this Section as the "Appellant"). Notwithstanding the filing of an appeal, the Appellant is required to pay any rates, tolls, charges, fines, fees, assessments, and penalties assessed by the District, and such rates, tolls, charges, fines, fees, assessments, and penalties shall be held by the District until such time as the appeal is final. The hearing and appeal procedures established below shall apply to all disputes concerning the interpretation, application or enforcement of the rates, tolls, charges, fines, fees, assessments, and penalties of the District and application

and enforcement of these Rules and Regulations, as they now exist or may hereafter be amended. In the event a proper and timely request for an appeal is not made as provided herein, the right to an appeal shall be deemed forever waived.

9.3.2 Appeal to the District Manager. If the Appellant wishes to dispute any rates, tolls, charges, fines, fees, assessments, or penalties imposed by the District, or a determination made by the District, the Appellant must first submit to the District a written request for an appeal to the District Manager within ten (10) days of being notified of a proposed revocation of Service or other determination of the District or of the due date specified for a rate, toll, charge, fine, fee, assessment, or penalty of the District. The request for appeal shall set forth with specificity the facts upon which the Appellant is relying and shall contain a brief but specific statement of the Appellant's reasons for the appeal. The request must include Appellant's correct mailing address.

Appellants should note the District Manager is obligated to apply the Rules and Regulations as written at the time, and is not authorized to consider or grant any variances from the Rules and Regulations not specifically set forth in those Rules and Regulations or in the District By-Laws.

Within thirty (30) days of receiving the request from the Appellant, the District Manager shall, after a full and complete review of the record, issue a written determination regarding the application or enforcement of the rates, tolls, charges, fines, fees, assessments, and penalties of the District or application and enforcement of these Rules and Regulations, as may be applicable. The written determination shall be sent to Appellant by certified mail return receipt requested (or by any mail delivery service that is the equivalent to or superior to certified mail return receipt requested). If Appellant provides a mailing address that is deemed undeliverable, Appellant shall be deemed to have failed to meet the requirements of this Section 9.3.2 and the timely appeal requirements of Section 9.3.1 shall be strictly applied.

9.3.3 Hearing Before Board of Directors.

9.3.3.1 Process for Requesting a Hearing. If the Appellant wishes to appeal the District Manager's written determination issued pursuant to Section 9.3.2 of these Rules and Regulations, the Appellant must submit to the District a written request for a hearing before the Board within ten (10) days of the date the District Manager's written determination issued pursuant to Section 9.3.2 of these Rules and Regulations was indicated as delivered to Appellant. The request for a hearing shall set forth with specificity the facts upon which the Appellant is relying and shall contain a brief but specific statement of the Appellant's reasons for the appeal. The request for a hearing shall indicate whether the Appellant will be represented by an attorney during the hearing for purposes of service of notice as set forth in Section 9.3.3.3 of these Rules and Regulations. The request must include Appellant's correct postal or electronic mail address (and the correct postal or electronic mail address of

Appellant's attorney if applicable), which will be used pursuant to Section 9.3.3.3. If Appellant fails to provide any address or provides any address that is deemed undeliverable, the request for a hearing shall be deemed deficient. In such a circumstance, the District shall schedule and hold a hearing on the deficient request, but the District shall be deemed to have complied with Section 9.3.3.3 delivery of notice of said hearing, Appellant shall be deemed to be on notice of the hearing pursuant to standard publication of the Board meeting agenda, and Appellant shall otherwise be deemed to be in receipt of and on notice of any and all Rules and Regulations for the hearing as set forth herein, including notice that the Board may establish rules and procedures governing the hearing and notice that the Board may preclude witnesses and exhibits not properly submitted to the District at least 10 days before the hearing. The Board shall hold a formal hearing on the appeal at the next regularly scheduled meeting that will be held no earlier than thirty (30) days after the receipt of the Appellant's request for a hearing.

9.3.3.2 Purpose of Hearing. The purpose of the hearing is to determine whether the District Manager's determination regarding the revocation of Service, other determination of the District, or the application or enforcement of a specified for a rate, toll, charge, fine, fee, assessment, or penalty of the District, as may be applicable, is not correct. Though the hearing phase of the appeal is not intended to be a forum for presenting, discussing, or making determinations on requests for variances from the Rules and Regulations, the Board may, in its sound discretion, make a determination that differs from these Rules and Regulations as the Board interprets them, as further set forth in Section 9.3.3.5. However, the Board, in its sound discretion, may discount or elect not to consider any issue addressed or relief requested by Appellant during the hearing which was not included in the request for a hearing as set forth in in Section 9.3.3.1.

9.3.3.3 Notice. A notice of the hearing shall be served on the Appellant, subject to the deficiency circumstances described in Section 9.3.3.1. The notice of the hearing shall be served by certified mail return receipt requested (or by any mail delivery service that is the equivalent to or superior to certified mail return receipt requested, including email), at least twenty (20) days before the hearing. Service may be made on any agent or officer of a corporation or company. When an Appellant is represented by an attorney, notice of any action, finding, determination, decision or order affecting the Appellant shall also be served upon the attorney and deemed service upon Appellant so long as the Appellant indicates representation by an attorney and provides a sufficient address in the request for a hearing as set forth in Section 9.3.3 .1 of these

Rules and Regulations.

The notice to Appellant shall:

- a.** Specify the date, time, and location of the hearing to be held by the Board;
- b.** Direct the Appellant, during the hearing, to present evidence of why the determination regarding the application or enforcement of the fee, rate or charge of the District or application and enforcement of these Rules and Regulations, as may be applicable, is not correct;
- c.** Direct the Appellant, at least ten (10) days before the hearing, to submit to the District a list identifying any individuals who will appear and/or testify on Appellant's behalf, the failure to do so may lead to preclusion of witnesses;
- d.** Direct the Appellant to, at least ten (10) days before the hearing, submit to the District a list of any and all exhibits and materials Appellant intends to introduce, discuss, or reference during the hearing, along with complete copies of the same, the failure to do so may lead to preclusion of exhibits and materials; and
- e.** Inform the Appellant the Board may establish rules and procedures governing the hearing such as, by way of example only and not as an inclusive list, time limitations for the presentation of evidence.

9.3.3.4 Conduct of Hearing. The hearing shall be recorded and open to the public during the regular course of the regularly scheduled monthly Board meeting. The Board may, at the beginning of the hearing, establish rules and procedures governing the hearing such as, by way of example only and not as an inclusive list, time limitations for the presentation of evidence. The hearing shall be administered by President of the Board or, if retained for a specific hearing, an independent Hearing Officer. The stages of the hearing shall be as follows:

- a.** The District's Manager shall first be entitled to summarize the written determination and present all evidence relevant and material to the issue. The District Manager may enlist District staff assistance in the presentation of evidence. The District's General Counsel shall inquire of the District Manager and any other witness presenting evidence or testimony on behalf of the District.
- b.** Upon conclusion of the District Manager's presentation of evidence, the Board may first examine or otherwise ask questions of

the District Manager. The Appellant (or Appellant's attorney if represented by an attorney) shall then be allowed to cross-examine the District Manager.

c. Upon conclusion of the District Manager's presentation of evidence, examination, and cross examination, the Appellant (or Appellant's attorney if represented by an attorney) is then entitled to present all evidence relevant and material to the issue, and to examine any witnesses put forth by Appellant. The District's General Counsel shall inquire of the Appellant and any other witness presenting evidence or testimony on behalf of the Appellant. The Board is entitled to cross-examine Appellant and any witnesses.

d. The Board shall then deliberate as the determining quasi-judicial body. During the deliberation stage (which shall be recorded and open to the public, unless recessed for a proper executive session only to receive legal advice concerning a specific legal question arising during the Hearing), the Board may, at any point, ask additional questions of the District Manager and any witnesses. The Board may, but is not obligated to, grant Appellant (or Appellant's attorney if represented by an attorney) leave for follow-up questions or additional cross-examination based narrowly on the Board's additional questions.

e. Upon conclusion of the Board's deliberation, the Board President shall solicit from the Board a motion to uphold, reverse, or, in the Board's sound discretion, modify the District Manager's written determination. The Board shall then vote on the respective motions, reach a final determination on the issue, and the hearing shall conclude.

9.3.3.5 Determination Standards of the Board. Any vote on the appeal shall require the affirmative vote of a majority of the Directors present and voting, as required by Section 8.b of the District's By-Laws, as the By-Laws may be amended from time to time. The Board may, in its sound discretion, vote on and thereby make a final determination that differs from these Rules and Regulations as the Board interprets them. Such a final determination effectively functions as a variance to the Rules and Regulations. But for the specific final determination made by the Board and such final determination's effective variance from the Rules and Regulations, neither the final determination nor the appellate process waives or otherwise modifies any other obligations of Appellants as set forth by these Rules and Regulations. Such a final determination's functional variance from the Rules and Regulations shall apply only to Appellant and shall not function as an amendment to or waiver of any provision of the Rules and Regulations generally. Alternatively, the Board may, in its sound discretion, determine the Appellant is

strictly bound by the Rules and Regulations and make a final determination based on its application of the subject facts in the record to the Rules and Regulations.

9.3.3.6 Written Final Determination. Based on the record established, the vote taken, and the final determination made, the Board shall issue a final written decision concerning the disposition of the appeal presented to it and shall cause notice and a copy of the final written decision to be sent by certified mail to the Appellant (and Appellant's attorney if represented by an attorney) within fifteen (15) days after the hearing.

9.3.3.7 Board of Directors Determination Final. The decision reached and final determination of the Board shall be final and binding upon the District and the Appellant and shall constitute the final administrative action of the District. Any party to the hearing aggrieved or adversely affected by an order and final determination of the Board may appeal such order and final determination to the District Court in and for the County of Jefferson, pursuant to Rule 106(a)(4) of the Colorado Rules of Civil Procedure.

9.4 Emergencies. If an Emergency is deemed to exist, the District may take any reasonable actions to remediate the Emergency, including, but not limited to immediately notifying the Colorado Department of Public Health and Environment or any other appropriate department or agency and disconnecting any Service Line from the District Facilities or taking any other action deemed necessary or prudent to protect the District, the District Facilities, and the Developers, Owners or Customers, until such time as the District has received adequate assurance that any and all violations of these Rules and Regulations have ceased or will cease and will not occur in the future and that such Emergency has been abated. The District will, as soon as reasonably possible, provide written notice as described in Section 9.2.1 of these Rules and Regulations.

GREEN MOUNTAIN WATER & SANITATION DISTRICT RULES AND REGULATIONS

APPENDICES TABLE OF CONTENTS

- **APPENDIX A:**
 - Rate and Fee Schedule
- **APPENDIX B:**
 - Drawings of Standards Details
- **APPENDIX C:**
 - Cross Connection Control and Backflow Prevention Rules and Regulations
- **APPENDIX D:**
 - Water and Sewer Main Testing Procedure
- **APPENDIX E:**
 - Grease and Sand Trap (INTERCEPTOR) Rules and Regulations.

APPENDIX A
SCHEDULE OF FEES, RATES AND CHARGES
Revised/Current as of December 09, 2025

A-1 WATER CHARGE:

Charges are calculated based on the water used multiplied by the applicable rate(s) set forth below and new water rates take starting January 1, 2026.

Residential Rates:

All water used shall be billed at the rate of \$7.31/1000 gallons

Multi-Family and ADU Rates:

All water used shall be billed at the rate of \$7.31/1000 gallons

Irrigation Rates:

0-8,000 gallons	\$7.12/1000 gallons
9,000-25,000 gallons	\$7.98/1000 gallons
26,000 + gallons	\$8.92/1000 gallons

Commercial Rates:

All water used shall be billed at the rate of \$7.98/1000 gallons

Denver Federal Center Rates:

All water used shall be billed at the rate of \$8.43/1000 gallons

A-2 SEWER CHARGE:

Charges are based on the usage multiplied by the applicable rate(s) set forth below. Bi-Monthly sewer charges for residential homes are calculated based on the water consumption indicated in the first winter billing of the previous year. This helps to avoid charging customers water used for outside irrigation on their sewer bills. For example: Water consumption for January or February 2025 = 10k gallons. Bi-Monthly

sewer rate for 2026 = \$55.40=(10 x \$5.54). New sewer rates take effect on January 1, 2026.

Residential Rate	\$5.54/1000 gallons
Tamarisk Sub-Division Lift Station	\$5.54/1000 gallons + \$9.50 lift station surcharge per billing
Multi-Family and ADU Rate	\$6.05/1000 gallons
Tamarisk Sub-Division Multi-Family Rate	\$6.05/1000 gallons + \$9.50 lift station surcharge per billing
Commercial Rate	\$6.05/1000 gallons
Denver Federal Center Rate	\$6.05/1000 gallons
Fossil Ridge Rate	\$6.93/1000 gallons

A-3 SERVICE FEE:

Residential	\$45.20 per billing
Multi-Family and ADU Rate	\$22.60 per unit per billing
Commercial	\$22.60 per SFRE per billing
Irrigation	\$22.60 per SFRE per billing
Denver Federal Center	Charged at the residential/multi-family/commercial rates above
Fossil Ridge	\$30.51 per SFRE per billing
Tamarisk Subdivision Lift Station	\$45.20 per billing
<i>Note: Duplexes are charged service fees per dwelling unit</i>	
Fireline SC	up to 4" \$8.00 per billing
	6" \$15.00 per billing
	8" \$25.00 per billing
	10" \$35.00 per billing
	12" and up \$70.00 per billing

A-4 Infrastructure Replacement Fee:

Residential	\$30.00 per billing
Multi-Family and ADU Rate	\$15.00 per unit per billing
Commercial	\$15.00 per SFRE per billing
Irrigation	\$15.00 per SFRE per billing

A-5 MISCELLANEOUS CHARGES:

1. Late Fee 5% on past due balance greater than \$20.00
2. Returned Check Fee \$30.00 or current bank rate per check

3. Returned ACH Direct Payment Fee	\$30.00 or current bank rate per check
4. Transfer Fee	\$45.00
5. Service Line Repair Permit Fee	\$50.00
6. Special Permit Fee	\$50.00
7. Meter Accuracy Test Fee:	Based on Denver Water Rates and size of the meter.
8. Additional Meter Profiles	First three in one calendar year free of charge. Additional profiles subject to current labor charges.
9. Damage to Water Meter	Property owner will be responsible for the cost of repair or replacement of the water meter at District's current cost.
10. Shut Off Fee:	1 st time \$50.00 2 nd time \$100.00 within 12 consecutive months. An additional shut-off fee of up to \$500.00 will be charged if customer turns water back on.

11. Design Review/Construction Fees/Charges

a. Hydrant permit	\$350.00
b. Market value refundable hydrant meter deposit	\$200.00 usage deposit. Deposit will be credited towards water usage bill(s) and upon notification that the Applicant will no longer be using the hydrant any remaining balance will be refunded to the Applicant. Market value Security/Damage deposit for the hydrant meter/backflow assembly.
c. Hydrant Meter Assembly	\$200.00 will be invoiced if hydrant meter is returned unusable.
d. Water use charges	Water use charges are billed at the current commercial rate.

e. Reimbursable District fees:

Any Applicant requesting Water and/or Sewer Service from the District shall be responsible for the payment of all legal, engineering and administrative fees and costs associated with the Water and/or Sewer Service, including, but not limited to, the design, construction and review process from initiation of the project through completion of the project (Actual Cost).

Prior to incurring substantial Actual Cost, the District may require that the Applicant enter into an agreement concerning payment of Actual Cost, including, but not limited to, provisions for an advance deposit by the Applicant to be used by the District to cover Actual Cost.

If the District requires an advance deposit, the District will set the amount of the deposit, based on the reasonably anticipated Actual Cost. The District shall hold the deposit in a non-interest-bearing escrow account and account for the deposit separately but shall not be required to maintain a separate bank account for the deposit. The deposit shall be retained by the District through the warranty period and applied against the last invoice rendered by the District for Actual Cost and such other costs as may be incurred by the District relating to the project (such as, for example, the cure of unfinished punch list items discovered on the last inspection, testing costs, or payment of maintenance or emergency response costs during the warranty period that are the responsibility of the Applicant).

The District shall have the right and authority to make disbursements from said escrow account at its sole discretion to cover the Actual Cost. Any balance remaining in the escrow account after the expiration of the warranty period shall be returned to the Developer without interest. If the initial deposit is exhausted before expiration of the warranty period, the Developer shall make a supplemental deposit to the escrow account in the amount to be determined by the District, in its reasonable discretion, to cover future costs and expenses resulting from the project. Failure to make such necessary supplemental deposits shall cause the District's work on the project to cease until the required deposits are made. The District's Manager, upon good cause shown to the District Manager's satisfaction, may reduce the amount of the initial deposit; however, the Applicant shall remain responsible for all Actual Cost related to the project.

If the District does not require an advance deposit, the Applicant will be billed by the District for the Actual Cost. If the Applicant does not timely make payment of such invoice Actual Cost the District may suspend all work on the project until such delinquent Actual Cost are paid in full and may at that time require an advance deposit to continue work on the project.

It is a condition of commencement of service to an Applicant, permitting a new water or sewer Tap to an Applicant, or continued service to an Applicant that any Actual Cost be paid in full.

The District shall have the right to assess any Applicant who is tardy in payment of the Actual Cost all legal, court and other costs necessary to or incidental to the collection of said account.

f. Inspection/Observation fees:

At all times during construction of water and sewer improvements, Green Mountain, its employees or agent/Engineer, has the right, in its discretion and without obligation, to inspect the improvements to ascertain that the materials and workmanship conform to the approved plans, standards and specifications. The Developer shall reasonably cooperate with and assist Green Mountain in gaining access to the areas designated for inspection.

The Developer shall pay fees imposed by the District to cover the costs incurred by the District in the inspection and mapping of tap connections, and main installations, payable to the District at the same time as System Development Fees. If multiple inspections are required because of poor installation or poor scheduling on the part of the Developer, Owner or Contractor, the Manager may charge additional fees based on costs, hourly rates and expenses incurred by the District as set forth in Appendix A.

If inspection services are provided by Green Mountain's Engineer, the actual costs shall be reimbursed. The Owner/Developer requesting or needing the inspection/observation shall deposit an amount estimated by Green Mountain to cover the fee for such inspection when the request for or notice of the needed inspection is made. Any unused portion of the deposit will be refunded. At least \$1,500.00 shall be kept on deposit at all times until the project is completed. If the deposit account falls below \$1,500.00, the deficit will be invoiced to the responsible party, and the account must be replenished before further inspections will be made. Construction shall not commence on any project requiring plan review or inspection by Green Mountain until deposits have been made.

- | | |
|---|---------------------|
| g. Distribution/collection main inspection fee: | \$3/per linear foot |
| h. Distribution/collection main tap inspection fee: | \$100.00 |

12. Penalty for Unauthorized Use of Hydrant Water		\$1,000.00
13. Penalty for Unauthorized Use of Fireline Water		\$1,000.00
14. Penalty for Violation of Rules and Regulations		Up to \$500 per violation
15 District Personnel	Hourly rates for District personnel will be charged based on the following basic service rate schedule. *	
	District Manager	\$170.00
	Supervisor	\$140.00
	Inspector	\$110.00
	Equipment Operator	\$120.00
	Mechanic	\$110.00
	Locator	\$90.00
	Skilled Laborer	\$90.00
	Office/Administrative	\$90.00

**Overtime will be charged at 1.5 times hourly rates; 10:00 pm to 6:00 am and holidays at 2 times hourly rates.*

16. Equipment	Hourly rates for District equipment will be charged based on the following basic service rate schedule.	
	Vac Truck	\$200.00
	TV Van	\$175.00
	Perm Liner	\$50.00
	Backhoe	\$130.00
	Tandem Axle Dump Truck	\$100.00
	Single Axle Dump Truck	\$75.00
	Equipment Trailer	\$29.00
	Repair Trailer w/ Tools	\$45.00
	Service Truck/Pickup	\$28.00
	Shoring Transport	\$35.00
	Skid Steer	\$110.00
	Plate Compactor	\$20.00
	Impact Breaker	\$40.00
	Hydraulic Broom	\$11.00
	Air Compressor	\$26.00
	Generator	\$38.00
	Trash Pump – 4”	\$16.00
	Submersible Pump – 3”	\$13.00
	Materials	Cost + 15%

If additional equipment has to be rented to complete the work they are doing, the charges for this equipment will be added to the applicable hourly rate(s).

17. Manual Meter Reading Charges: \$50.00 in the First Billing Cycle/year
 \$125.00 in the Second Billing Cycle/year

A third billing cycle/year without changing the meter may result in revocation of water service to the property.

Imposed upon any property owner who has not scheduled and kept an appointment at which the District, its agents, employees and/or contractor could replace his/her water meter after the District has mailed 2 or more letters or notices to the property address or billing address requesting that such an appointment be scheduled.

18. Grease Trap Violations: Properties that fail to service a grease trap when necessary and notified by the District will be subject to fines up to \$200.00 per day until corrected.

19. Water Waste Violation: In the event that the District has identified and communicated to the Owner that water waste/water leaks are present at the Owner's property, the Owner shall have one week to make necessary repairs to said water waste/water leaks. If no repairs are made, the District may shut off service until repairs can be made as well as assess a water waste violation fee of \$100.

20. Backflow Annual Test Violation: Owner will receive annual backflow testing letter one month prior to test month. Owner has entire test month to have testing completed. Backflow testing is considered out of compliance on the first day after test month. Second notice letter is sent to owner 1 week post test month. Third notice letter is sent to owner 1 day after second post test month. Owner will receive a phone call the second week after second post test month. Owner will receive a shut off notice and \$500 fine 1 day after third post test month. Owner will receive additional shut off fee of \$100 when water service is interrupted.

A-6 WATER SYSTEM DEVELOPMENT FEE (SDF):

Water Service lines/Meter Size	SFREs	Fee
--------------------------------	-------	-----

5/8"x 3/4", or 3/4"	1	\$ 20,011.00
1"	3	\$ 60,033.00
1-1/2"	6	\$ 120,066.00
2"	9	\$ 180,099.00
3"	17	\$ 340,187.00
Fees for taps larger than 3" will be Determined by the Board of Directors		

Residential Units:	SFRE	Fee
Development fee for Single Family Duplexes, ADU & Multi-Family Residential		
Small sized. Shall not have more than 1 bedroom or be larger than 750 sq ft.	0.7	\$ 14,007.70
All other Single Family Duplexes, ADU & Multi-Family Residential	1.0	\$ 20,011.00

A-7 SEWER SYSTEM DEVELOPMENT FEE:

The fee per Single Family Home, for each Duplex, ADU & Multi Family residential unit, and other user classes shall be in accordance with the following Equivalent Residential Unit (EQR) Schedule.	Fee
	\$ 13,600.00
*Current Metro Water Recovery SDF fee collected by the District	*current fee

EQUIVALENT RESIDENTIAL UNIT (EQR) SCHEDULE:

For the setting of certain fees the District has adopted an Equivalent Residential Unit Schedule. The base for this schedule is an average detached single-family residence, or its equivalent. The schedule is given in the following table.

CLASS OF USER		EQR
A. RESIDENTIAL CLASSIFICATIONS		
1. Single-family Residential Units (per each)		1.0
Single-family homes, individually billed mobile homes, mobile homes on single lots, mobile homes established for permanent residences.		
<i>Note: Rental privileges of all kinds are prohibited.</i>		
2. Multi-family Residential Units (per unit):		
Apartments, Accessory Dwelling Units, condominiums, duplexes, townhouses, and similar facilities in the same complex, small cabins in courts not associated with motels; all units intended for long-term rental or ownership.		
• Small sized. Shall not have more than 1 bedroom or be larger than 750 sq ft.		0.7
• Any larger unit.		1.0
3. Transient Residential Units:		
Hotels, motels, mobile home parks, dormitories and similar facilities.		
a. Manager’s Unit (per each)		0.8
b. Motels, hotels and rooming houses without kitchen		
• with not more than 2 bed spaces per room (per each rental room)		0.2
• with more than 2 bed spaces per room (per each room)		0.35
<i>Note: Includes: laundry facilities in mobile homes; swimming pools and laundry facilities (except those in mobile homes) are additive; room counts shall include rooms furnished to employees. Each billing unit shall have a minimum of one Manager’s unit.</i>		
c. Motels with kitchen facilities		
• with not more than 2 bed spaces per unit (per each rental unit)		0.3
• with more than 2 bed spaces per unit (per each rental unit)		0.4
d. Dormitories (per each rental bed space)		0.1
e. Add for laundry facilities (or available hookup) in each building, % of total EQR served.		20%

CLASS OF USER	EQR
f. Mobile homes in park – with laundry	0.80/space
B. COMMERCIAL CLASSIFICATION	
1. Restaurants and Bars:	
Restaurants, bars, lounges, banquet rooms and drive-ins	
a. Restaurants and bars (per 10 seats)	1.0
b. Banquet Rooms (per 10 seats)	0.4
c. Drive-ins (per car stall).	0.3
d. Drive thru take out service window	0.5
2. Commercial Buildings:	
Office buildings, retail sales buildings, multiple use buildings, Laundromats, service stations, shops, garages and similar facilities.	
a. Offices and office buildings (per 1,000 sf of gross floor area)	0.5
b. Retail sales area (per 1,000 sf of gross usable area, includes sales, storage and support areas, but not including food service (which is separately assessed)	0.3
c. Laundromats (per washing machines)	1.20
d. Service Stations (a set of pumps is defined as 2 pumps regardless of the number of hoses)	
• first set of pumps	1.2
• each additional set of pumps (per set)	0.8
• add for each bay/rack where cars can be washed	1.4
e. Non-retail work areas such as garages, machine shops. (per each 10 employees)	0.7
f. Movie theaters (per each 50 seats)	1.0
<i>Note: No process water will be allowed to enter the sewer.</i>	
C. CHURCH AND SCHOOL CLASSIFICATIONS	
1. Churches (per 100 seats)	1.0
<i>Notes: Rectories, social areas with kitchen facilities are separately assessed additive.</i>	
2. Day care centers, public and private day schools	
• Without gym and without cafeteria (per 50 students)	1.40
• Without gym and with cafeteria or with gym and without cafeteria (per 50 students)	1.75
• Without gym and with cafeteria (per 50 students)	2.10
<i>Notes: Includes teachers, librarians, custodians, and administrative personnel associated with the school function; administrative centers,</i>	

CLASS OF USER

EQR

warehouses equipment (such as buses) repair and/or storage centers, swimming pools and similar facilities are separately assessed additive.

D. MISCELLANEOUS CLASSIFICATIONS

1. Swimming pools and wading pools

Commercial and public pools. Total EQR to be computed from pool volume and per capital capacity as follows:

- first 40,000 gallons of pool volume 1.05
- each additional 40,000 gallon capacity 0.75

Notes: A permanent sign must be placed prominently at all pool filter installations stating that pools are not to be drained without permission from the District Manager, that pool draining rates will be subject to approval of the District, and that draining shall be limited to the hours between 11 p.m. and 6 a.m. the next day.

2. Recreational Vehicle Waste Disposal Stations

The operator of the disposal facility shall provide a means acceptable to the District of counting the number of times the disposal facilities are used.

The District shall review and approve charges made to users of dumping facilities by facility owners; no system development fees will be assessed for camper dump facilities, and the District reserves the right to cease service to such facilities at any time.

3. Medical Hospital

- per bed 0.6

Note: Includes staff and administrative personnel associated with the hospital function.

4. Assisted Living Facility – per unit 0.4

5. Public Restrooms (per toilet or urinal) 0.2

E. OTHER CLASSIFICATIONS

Equivalents shall be established on an individual basis for all users other than those identified in Classifications A, B, C, and D above. Industrial users will be subject to the requirements of the Environmental Protection Agency as those requirements pertain to assessment of user’s charges and cost recovery (refer to 40 CFR, Part 35). (1987)

F. GENERAL NOTES:

CLASS OF USER

EQR

Each customer of the system will be charged a minimum of 1 EQR for purposes of establishing fixed costs.

Any customers who do not fit any of the previously mentioned classifications will be determined by the District.

**APPENDIX B
DRAWINGS OF STANDARD DETAILS**

TABLE OF CONTENTS

Detail #	
1.	Typical As-Built Drawing
2.	Water Main and Service Line Bedding & Backfill Details
3.	Sewer Main and Service Line Bedding & Backfill Details
4.	Fire Hydrant Detail
5.	Sanitary Sewer Manhole with pre-cast base
6.	Cast in place Sanitary Sewer Manhole
7.	Drop Manhole
8.	Vertical Thrust Block Detail
9.	Sewer Crossing Detail
10.	Pipe Encasement Detail
11.	Typical Potable Service Line Installation
12.	Water Meter Detail – 5/8" x 3/4", 3/4", & 1"
13.	Large Water Meter Detail 1-1/2" & 2" Meters
14.	Sewer Service Connection Detail
15.	Service Line Clean-out Detail

- (A) LOCATE WATER LINE BENDS.
- (B) LOCATE WATER LINE TEES & CROSSES.
- (C) LOCATE ALL VALVES, SERVICES & MAINS.
- (D) LOCATE ANY SPECIALTY ITEMS. (E.G. FIRE HYDRANTS, METER VAULTS, ARV VAULTS, PRV VAULTS, COUPLINGS, ETC...)
- (E) NOTE DISTANCES TO EDGE OF PAVEMENT AND TO R.O.W. OR EASEMENTS.
- (F) LOCATE ALL SERVICE TAPS AND LINES.
- (G) NOTE ANY KNOWN R.O.W. AND EASEMENT INFORMATION.
- (H) NOTE FINAL INVERT ELEVATIONS W/BENCHMARK ELEVATION REFERENCED.
- (J) NOTE LENGTH, SIZE, MATERIAL AND SLOPE OF LINE AS INSTALLED.
- (K) NOTE DISTANCES BETWEEN UNDERGROUND UTILITIES.
- (L) NOTE PERMANENT EASEMENT MONUMENTS AND PROPERTY CORNERS (PC) WHERE USED FOR TIES.
- (M) NOTE SERVICE STREET ADDRESSES.

AS-BUILT DRAWINGS TO SCALE

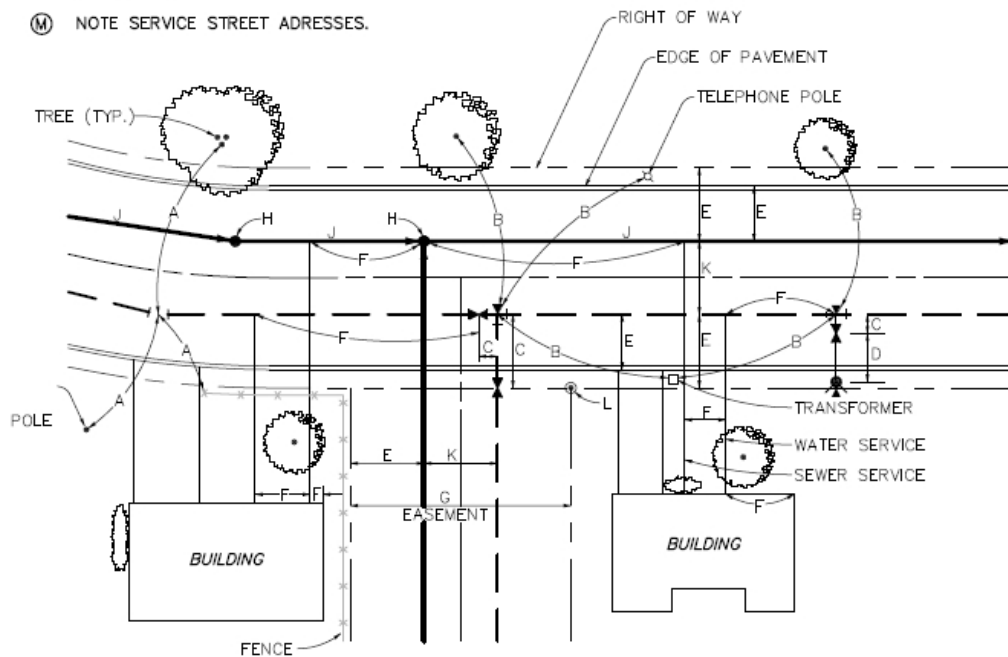

(AS BUILT TO BE SEALED BY THE DESIGN ENGINEER)

DRAWINGS TO BE FURNISHED IN AUTOCAD FORMAT

FINAL APPROVAL FOR JOB WILL NOT BE GIVEN UNTIL AS-BUILTS ARE DELIVERED TO THE DISTRICT.

TYPICAL "AS BUILT" DRAWING INFORMATION

REFER TO DISTRICT STANDARDS FOR ADDITIONAL REQUIREMENTS

THESE DETAILS ARE PROVIDED FOR STANDARDIZATION PURPOSES ONLY. THIS DETAIL PRESENTS MINIMUM DESIGN STANDARDS WHICH MAY REQUIRE UPGRADING FOR SPECIFIC APPLICATIONS.

Green Mountain Water and Sanitation District

STANDARD DETAILS

DATE: 7-15-2005

Laughlin Rincon

Detail 1

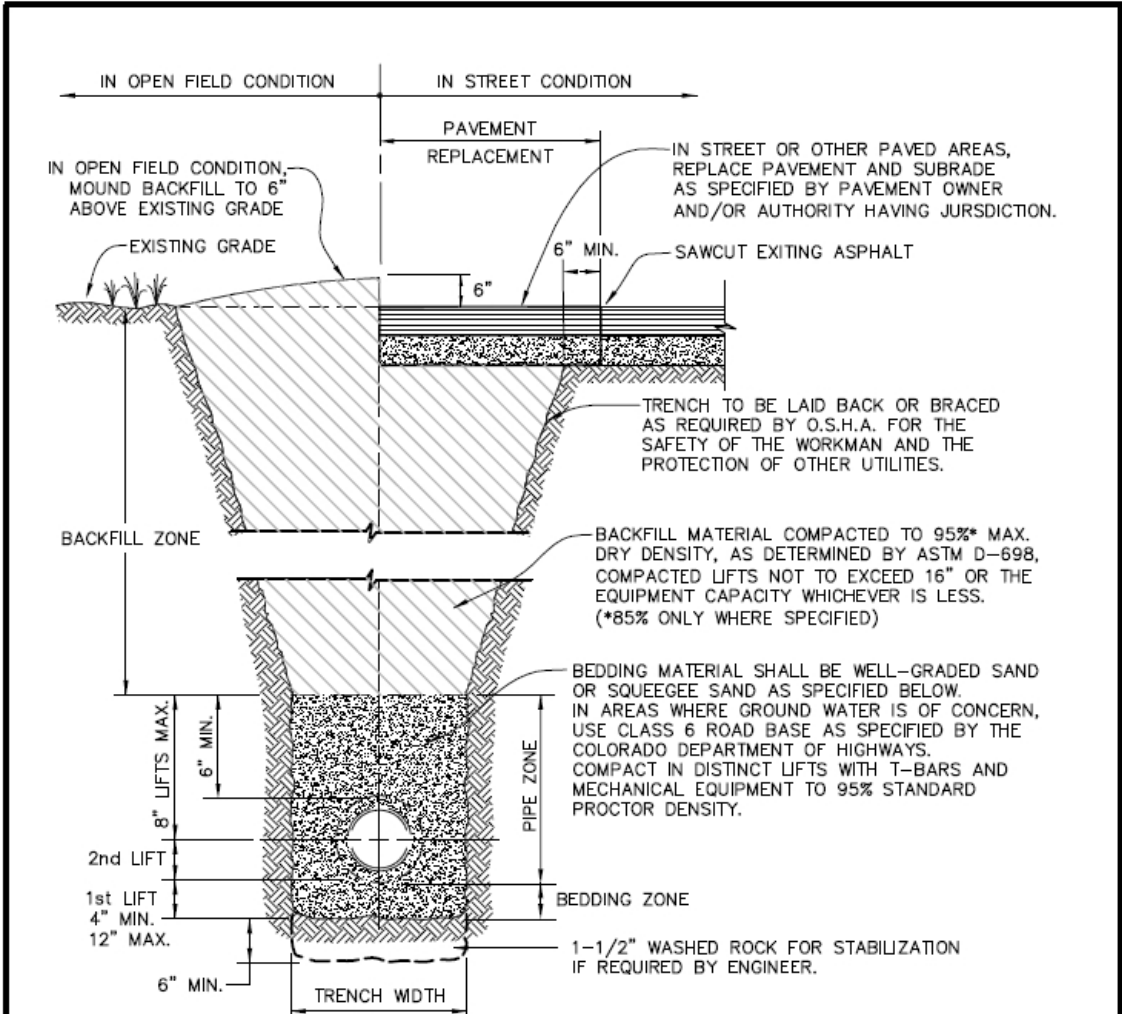

BEDDING MATERIAL:

WELL-GRADED SAND		SQUEEGEE SAND	
SIEVE SIZE	% PASSING	SIEVE SIZE	% PASSING
3/8"	100	3/8"	100
NO.4	70-100	NO. 200	0-5
NO.8	36-93		
NO.16	20-80		
NO.30	8-65		
NO.50	2-30		
NO.100	1-10		
NO.200	0-3		

% PASSING IS TOTAL PERCENT PASSING BY WEIGHT.

TRENCH WIDTH SHALL CONFIRM TO THE FOLLOWING:

PIPE I.D.	MIN. WD.	MAX. WD.
4" & SMALLER	1'-4"	2'-4"
6"	1'-6"	2'-6"
8"	1'-8"	2'-8"
12"	2'-0"	3'-0"
16"	2'-4"	3'-4"
20"	2'-8"	3'-8"
24"	3'-0"	4'-0"

WATER MAIN & SERVICE BEDDING & BACKFILL DETAILS

REFER TO DISTRICT STANDARDS FOR ADDITIONAL REQUIREMENTS
 THESE DETAILS ARE PROVIDED FOR STANDARDIZATION PURPOSES ONLY. THIS DETAIL REPRESENTS MINIMUM DESIGN STANDARDS WHICH MAY REQUIRE UPGRADING FOR SPECIFIC APPLICATIONS.

Green Mountain Water and Sanitation District

STANDARD DETAILS

DATE: 7-15-2005



Detail 2

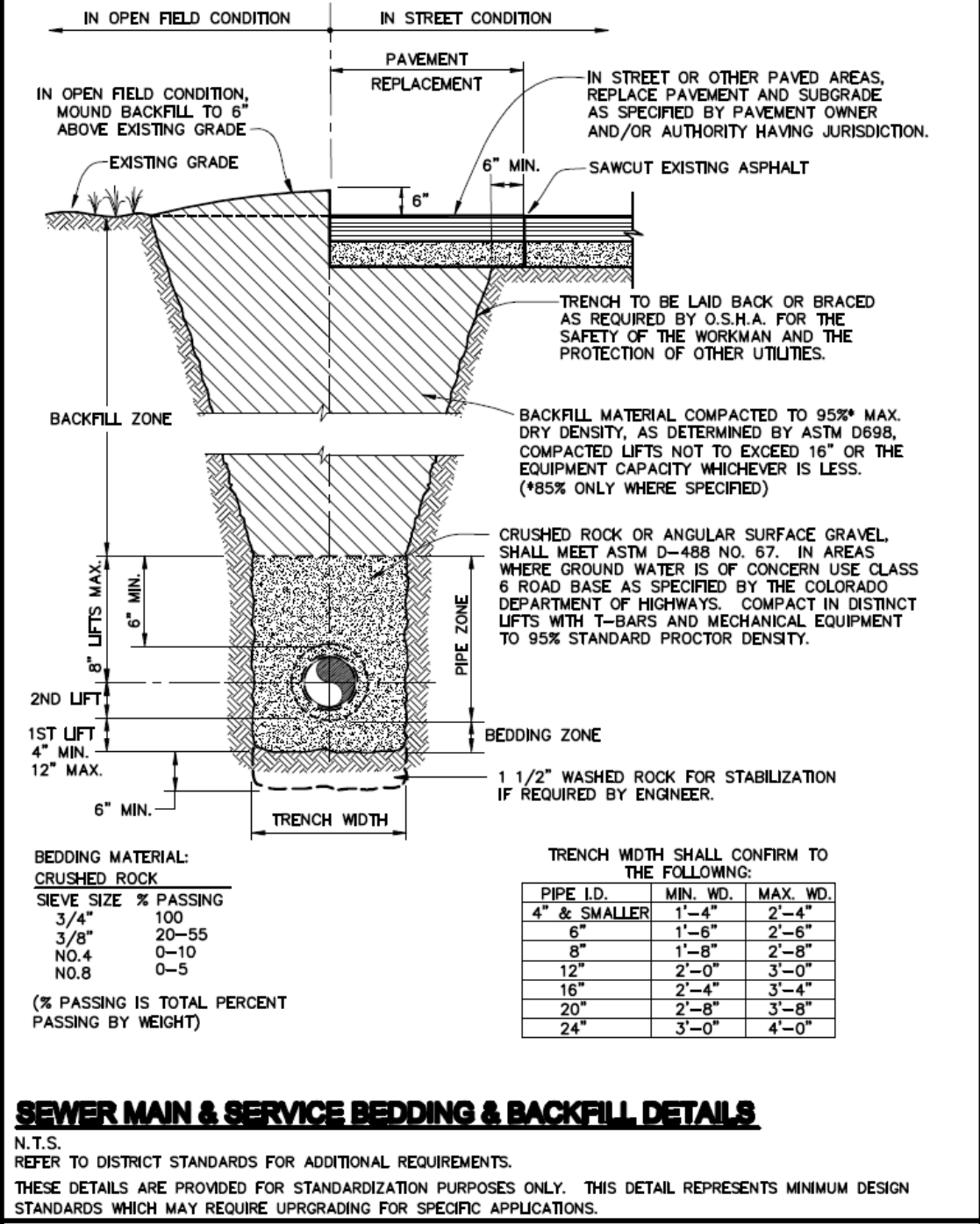

SEWER MAIN & SERVICE BEDDING & BACKFILL DETAILS

N.T.S.
 REFER TO DISTRICT STANDARDS FOR ADDITIONAL REQUIREMENTS.
 THESE DETAILS ARE PROVIDED FOR STANDARDIZATION PURPOSES ONLY. THIS DETAIL REPRESENTS MINIMUM DESIGN STANDARDS WHICH MAY REQUIRE UPGRADE FOR SPECIFIC APPLICATIONS.

Green Mountain Water and Sanitation District

P:\PROJECTS\Green Mountain Water & San Dist 03-53\03-53-00 General Services\Standard Detail Dwg\standard_details_2005.dwg

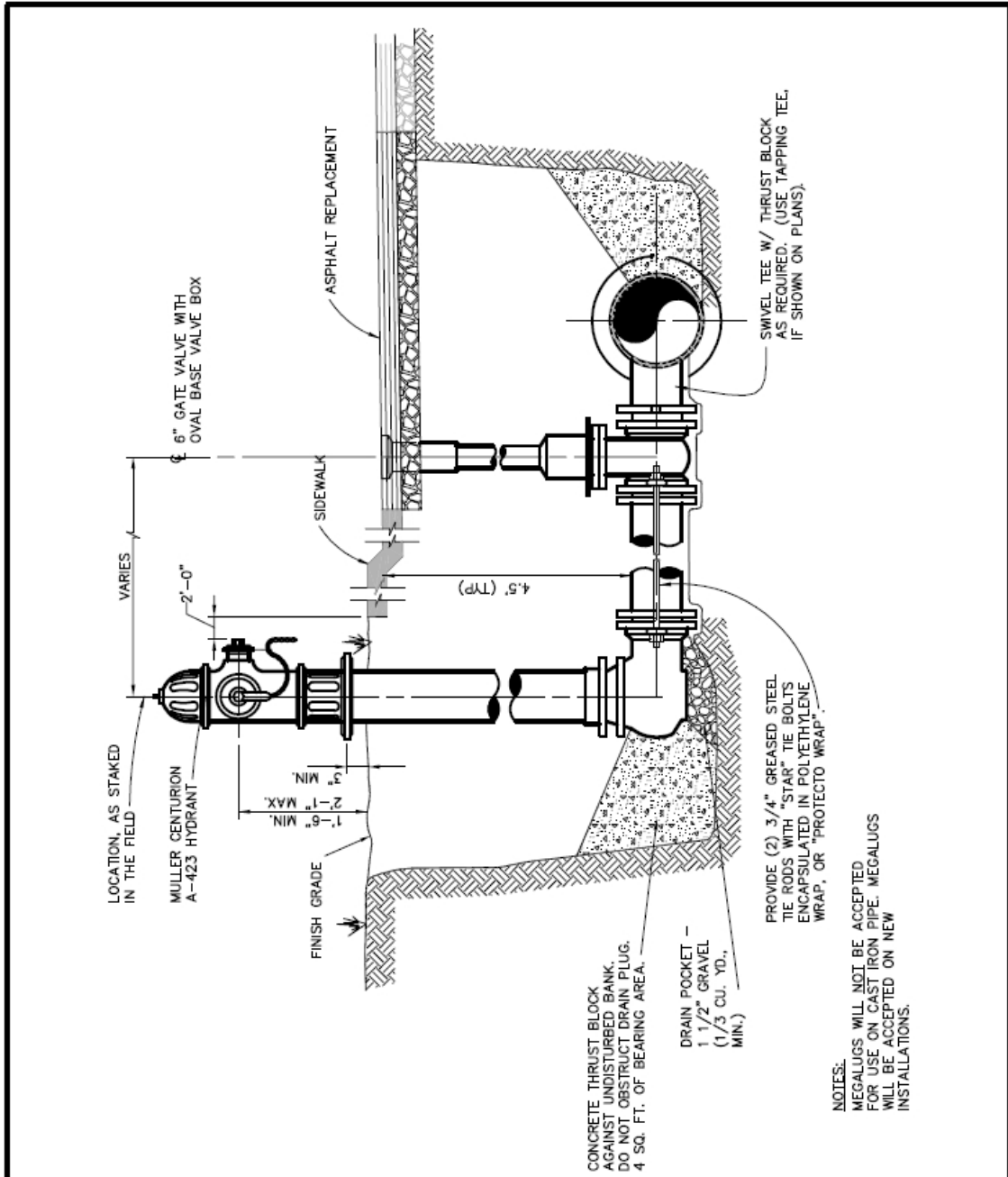

FIRE HYDRANT DETAIL

REFER TO DISTRICT STANDARDS FOR ADDITIONAL REQUIREMENTS

THESE DETAILS ARE PROVIDED FOR STANDARDIZATION PURPOSES ONLY. THIS DETAIL REPRESENTS MINIMUM DESIGN STANDARDS WHICH MAY REQUIRE UPGRADING FOR SPECIFIC APPLICATIONS.

Green Mountain Water and Sanitation District

STANDARD DETAILS

DATE: 7-15-2005



Detail 4

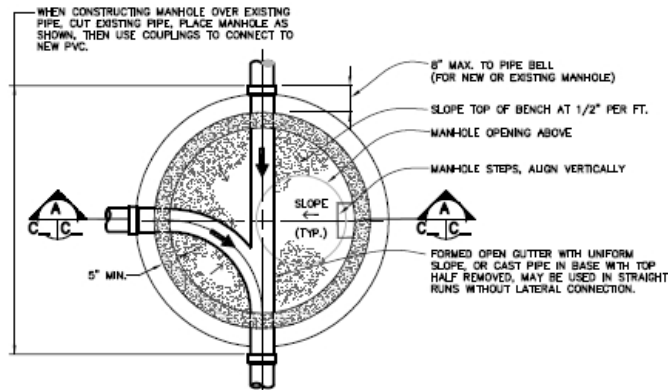

BASE WITH LATERAL PIPE

PLAN
 $1/2" = 1'-0"$
 $1/2" = 1'-0"$

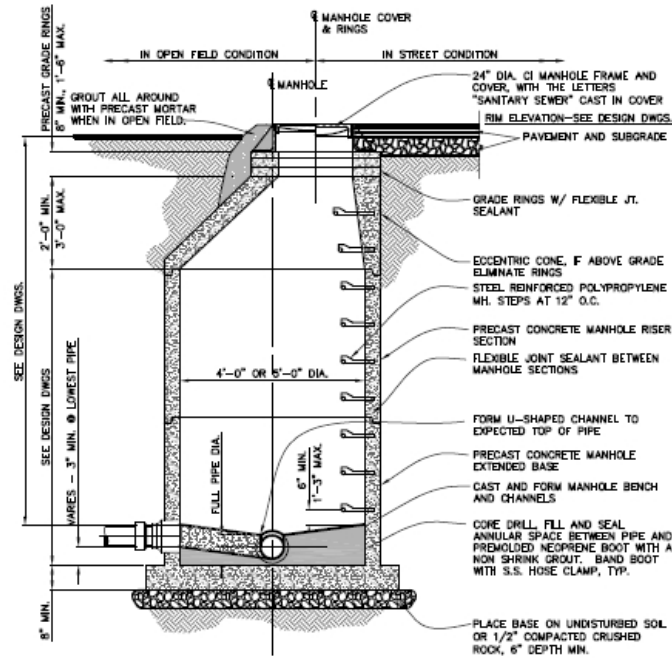

SECTION
 $1/2" = 1'-0"$
 $C-C$

**SANITARY SEWER MANHOLE
 W/ PRECAST BASE**

Green Mountain Water and Sanitation District

STANDARD DETAILS

DATE: 7-15-2005



Detail 5

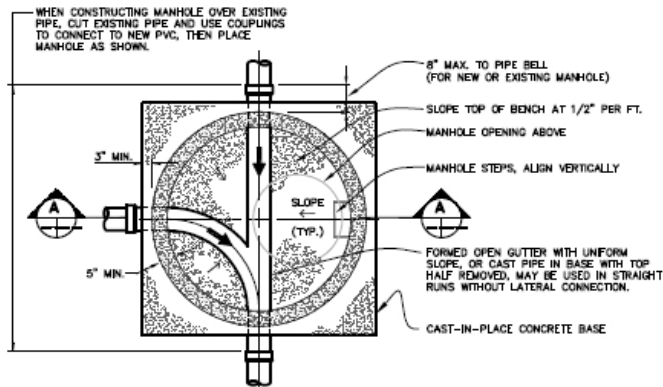

BASE WITH LATERAL PIPE

PLAN
1/2" = 1'-0"

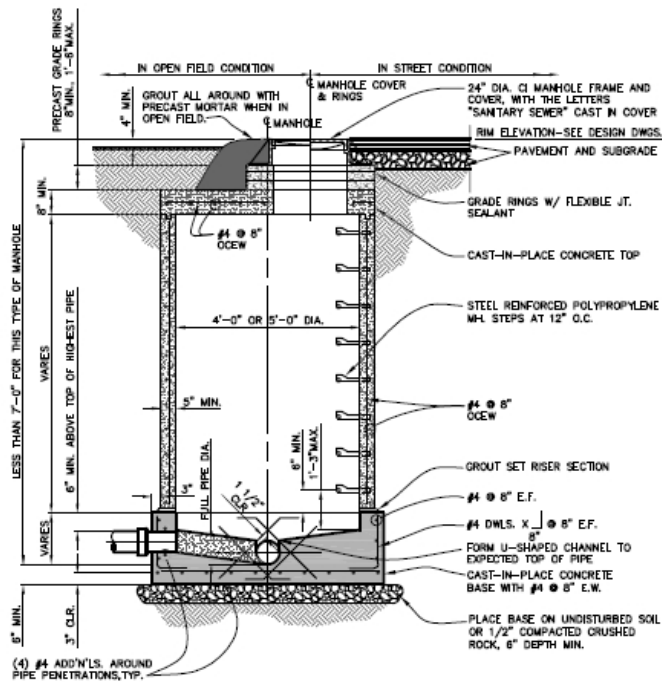

SECTION
1/2" = 1'-0"

CAST-IN-PLACE SANITARY MANHOLE

NOTE:
EACH INSTALLATION
MUST BE APPROVED BY THE
DISTRICT ENGINEER.

Green Mountain Water and Sanitation District

STANDARD DETAILS

DATE: 7-15-2005



Detail 6

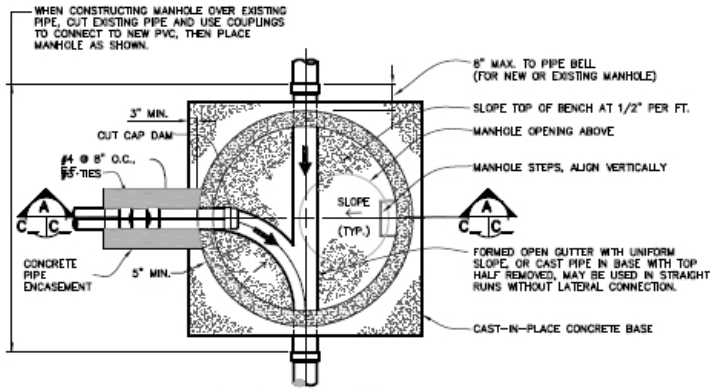

BASE WITH LATERAL PIPE
PLAN
 1/2" = 1'-0"

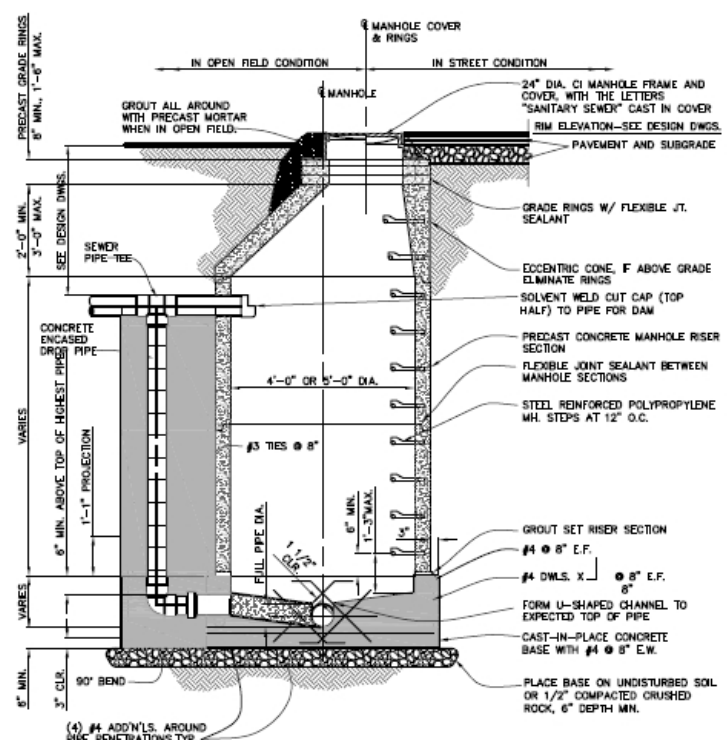

SECTION
 1/2" = 1'-0"
DROP MANHOLE

Green Mountain Water and Sanitation District

STANDARD DETAILS

DATE: 7-15-2005



Detail 7

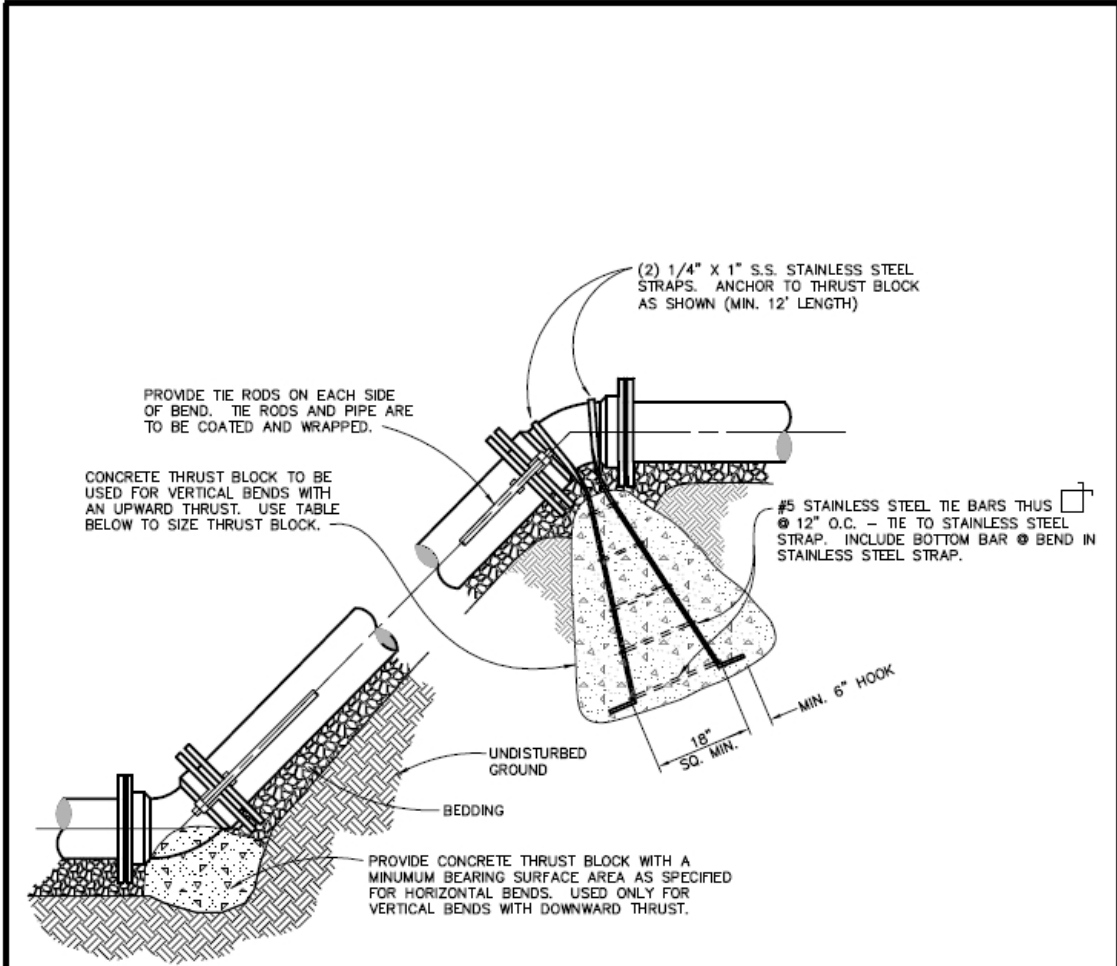

MINIMUM VOLUME OF CONCRETE FOR UPPER FITTING VERTICAL THRUST BLOCK IN CU. YDS.

PIPE SIZE	11-1/4° BEND	22-1/2° BEND	45° BEND
4"	0.2	0.3	0.5
6"	0.3	0.6	1.1
8"	0.5	1.0	1.7
10"	0.8	1.4	2.7

VERTICAL THRUST BLOCK DETAIL
NTS

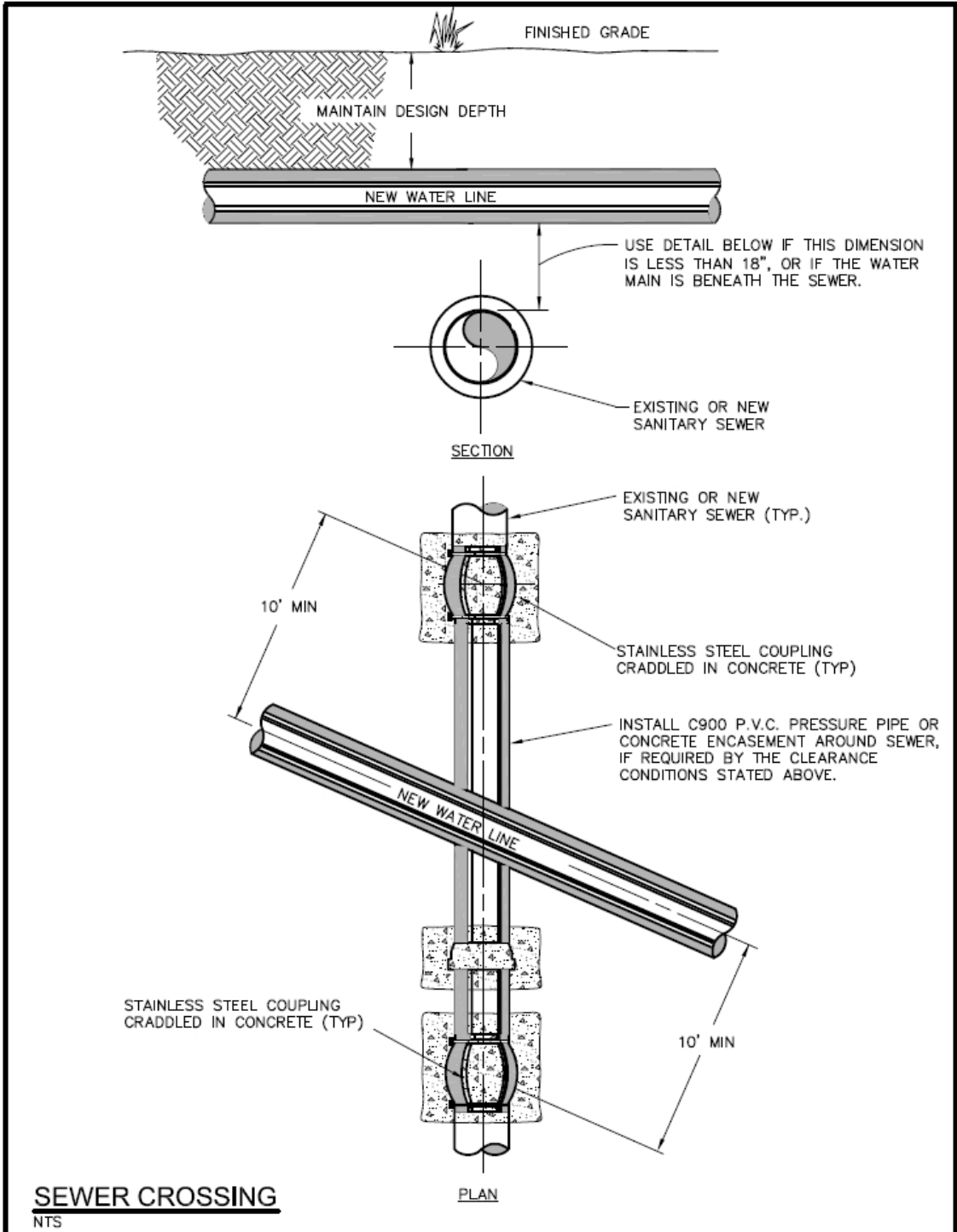

Green Mountain Water and Sanitation District

STANDARD DETAILS

DATE: 7-15-2005



Detail 9

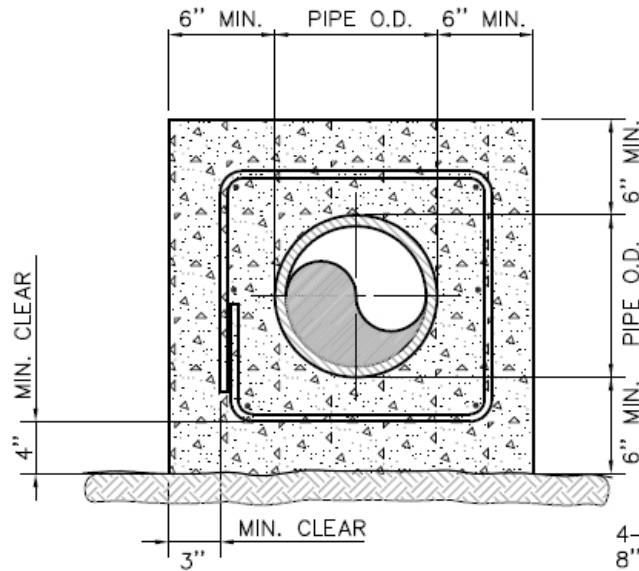

4-NO. 5 BARS CONTINUOUS FOR
8" PIPE AND 6-NO. 5 BARS
CONTINUOUS FOR 10" OR LARGER.

NO. 4 TIES AT 18" O.C.

NOTE:

1. CONCRETE SHALL NOT BE LEANER THAN 1 CEMENT; 2-1/2 SAND;
5 STONE AND SHALL NOT HAVE LESS THAN 3,000 PSI
COMPRESSIVE STRENGTH AT 28 DAYS.
2. PLACE CONCRETE AGAINST EITHER SOLID FORMWORK OR
UNDISTRUBED SOIL.
3. USE GR. 40 REINFORCING BARS.

PIPE ENCASEMENT DETAIL

Green Mountain Water and Sanitation District

STANDARD DETAILS

DATE: 7-15-2005



Detail 10

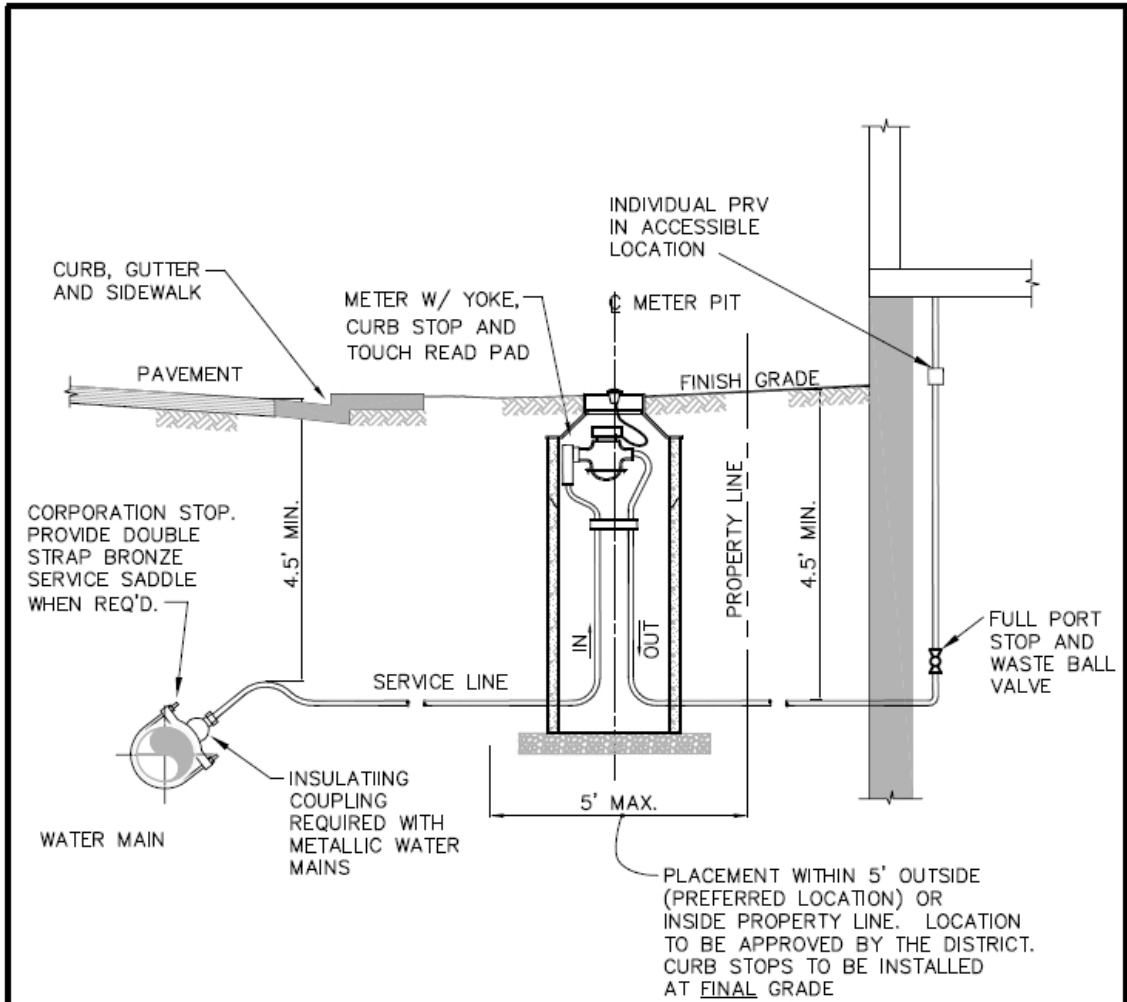

GENERAL NOTES:

1. Service line to be type "K" copper.
2. District owns main, service tap, corporation stop, meter and touch read pad.
3. Service owner owns meter pit, cover and lid and the remainder of service facilities shown.
4. Service line and meter pit to be inspected by the District.
5. Install individual pressure reducing valve (PRV) unless specifically not required by the District Engineer. Alternate location for PRV in meter pit.
6. The Owner owns the entire line (except the water meter) from the tap all the way into the structure.

Typical Potable Water Service Line Installation

THESE DETAILS ARE PROVIDED FOR STANDARDIZATION PURPOSES ONLY. THIS DETAIL REPRESENTS MINIMUM DESIGN STANDARDS WHICH MAY REQUIRE UPGRADING FOR SPECIFIC APPLICATIONS.

Green Mountain Water and Sanitation District

STANDARD DETAILS

DATE: 7-15-2005



Detail 11

- (A) 90° BEND
- (B) TEE
- (C) CURB STOP OR BALL VALVES
- (D) METER, SEE NOTE 4
- (E) CHECK VALVE
- (F) TYPE "K" COPPER
- (G) PIPING CHANGE REQ'D ON 1-1/2" & 2" METERS.
- (H) DRILL MANHOLE LID FOR TOUCH READ PAD 1-7/8".

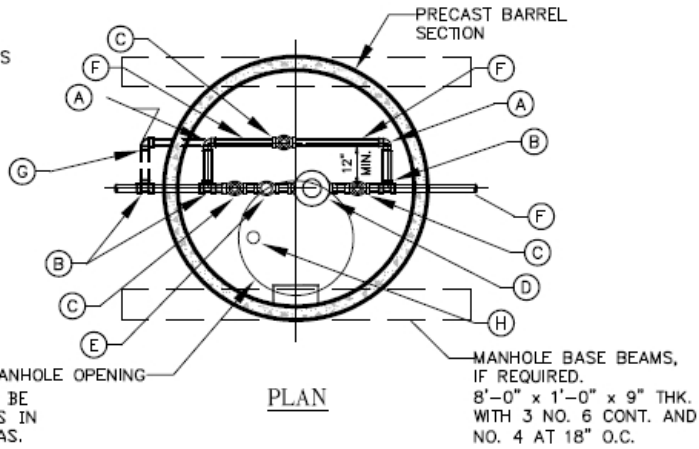

GENERAL NOTES

1. MANHOLE BASE BEAMS SHALL BE REQUIRED FOR INSTALLATIONS IN DRIVEWAYS OR PARKING AREAS.
2. JOINTS INSIDE METER VAULT SHALL BE EITHER THREADED OR SOLDERED WITH 95/5% TIN/ANTIMONY SOLDER.
3. METER SHALL BE SENSUS TYPE SR W/ TOUCH READ/PIT LID ADAPTER METERS SHALL BE FLANGED WITH BRASS COMPANION FLANGES AND STAINLESS STEEL BOLTS.
4. NO CHANGES IN PIPE DIAMETER SHALL BE MADE IN THE METER PIT OR BEYOND THE METER PIT ON THE OUTLET SIDE.
5. MANHOLE STEPS SHALL BE PLACED ON THE OPPOSITE SIDE OF BYPASS AT 16" O.C. STEPS TO BE NEENAH R-1982-W OR EQUAL.
6. LAWN SPRINKLER CONNECTIONS SHALL BE A MINIMUM OF FIVE FEET FROM THE METER PIT WALL ON THE OUTLET SIDE.
7. IF SURFACE IS NOT TO FINAL GRADE AT THE TIME OF INSTALLATION OF METER, OWNER MUST RAISE OR LOWER PIT WHEN SURFACE IS GRADED.
8. IN AREAS OF GROUNDWATER, USE A CAST IN PLACE 6" THICK CONCRETE BASE, 6'-0" DIA., WITH NO. 4 BARS AT 12" O.C. EACH WAY. INSTALL 4" PVC DRAIN TO DAYLIGHT. PLACE BASE ON 1-1/2" COMPACTED WASHED ROCK FOR STABILIZATION.

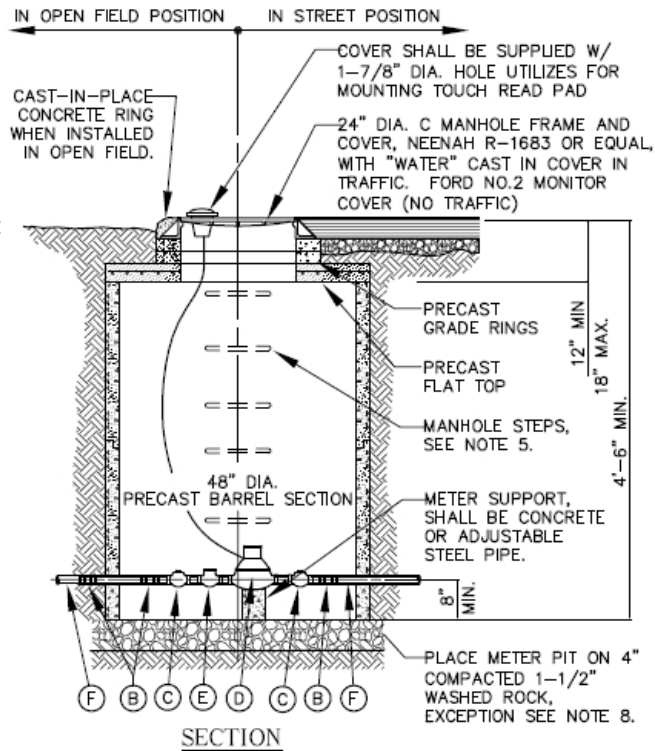

Water Meter Detail - 1-1/2" & 2"

THESE DETAILS ARE PROVIDED FOR STANDARDIZATION PURPOSES ONLY. THIS DETAIL REPRESENTS MINIMUM DESIGN STANDARDS WHICH MAY REQUIRE UPGRADING FOR SPECIFIC APPLICATIONS.

Green Mountain Water and Sanitation District

STANDARD DETAILS

DATE: 7-15-2005



Detail 13

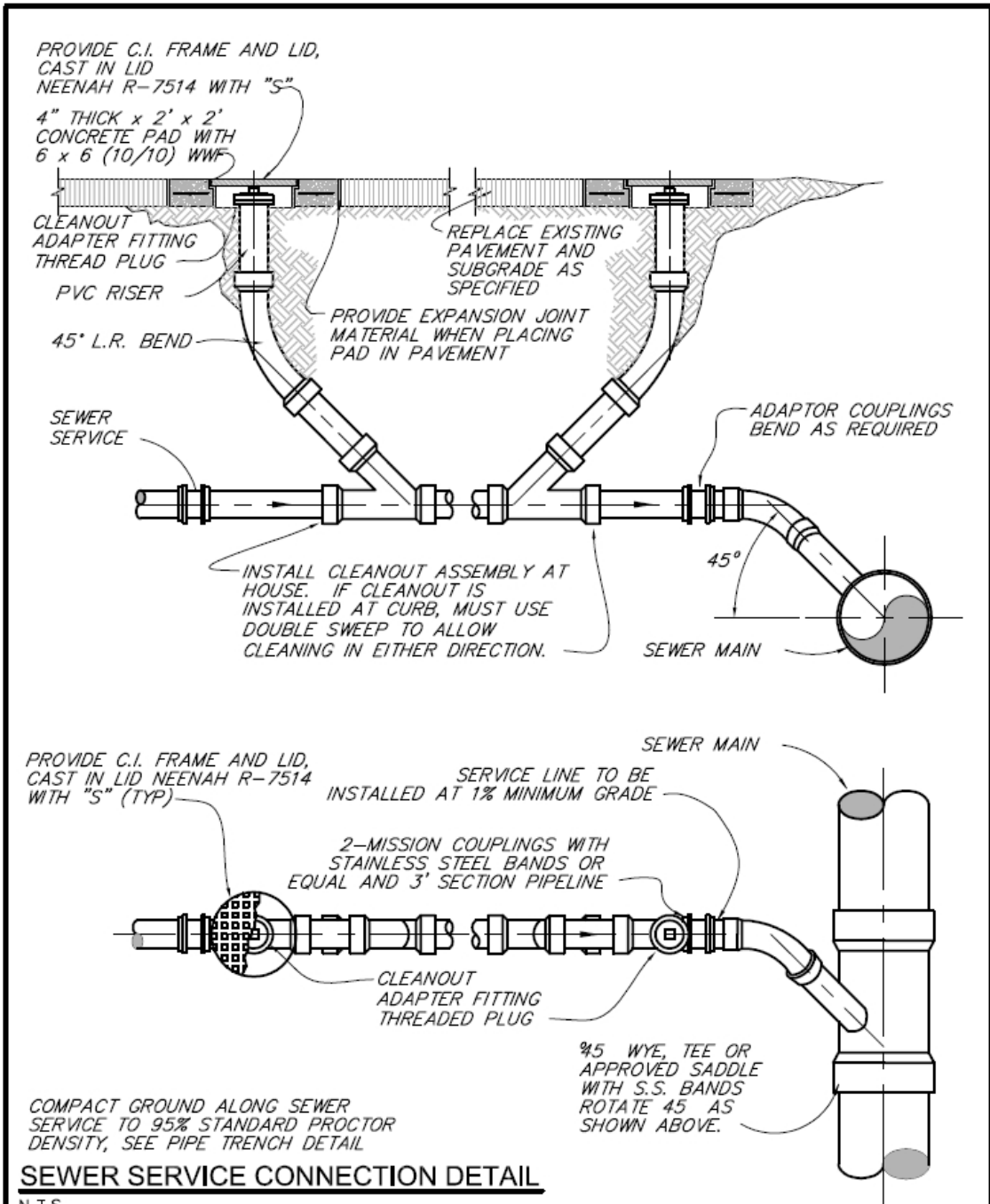

SEWER SERVICE CONNECTION DETAIL

N.T.S.

REFER TO DISTRICT STANDARDS FOR ADDITIONAL REQUIREMENTS

THESE DETAILS ARE PROVIDED FOR STANDARDIZATION PURPOSES ONLY. THIS DETAIL REPRESENTS MINIMUM DESIGN STANDARDS WHICH MAY REQUIRE UPGRADING FOR SPECIFIC APPLICATIONS.

Green Mountain Water and Sanitation District

STANDARD DETAILS

DATE: 7-15-2005



Detail 14

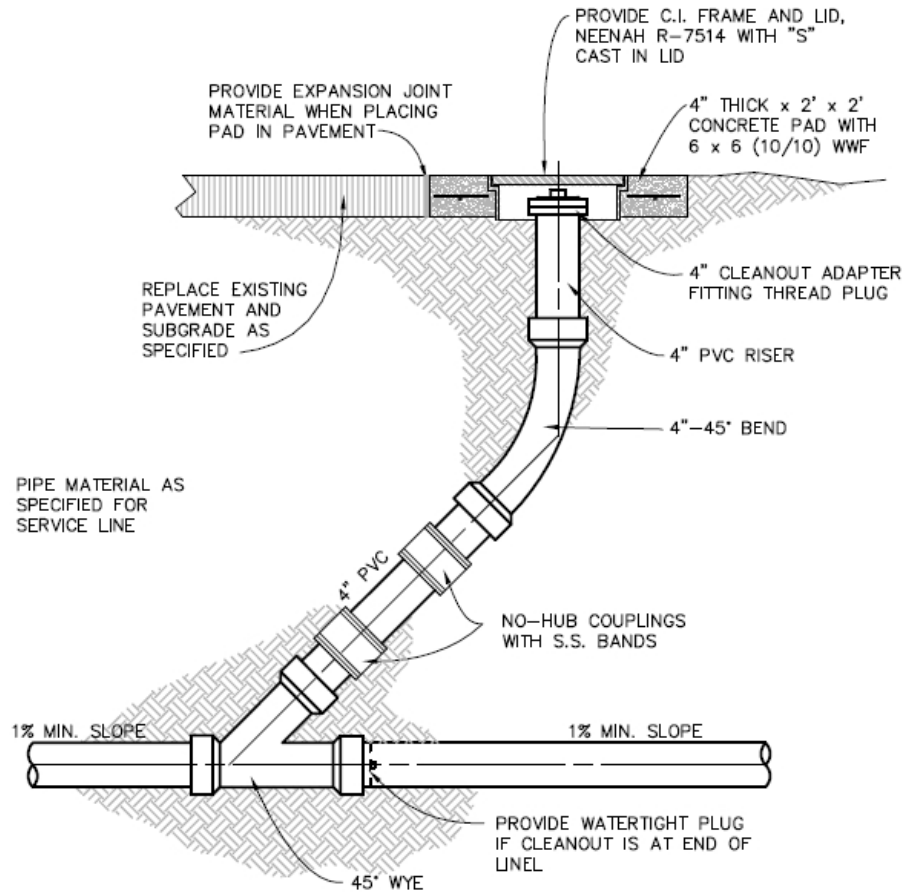

SERVICE LINE CLEANOUT DETAIL

REFER TO DISTRICT STANDARDS FOR ADDITIONAL REQUIREMENTS
 THESE DETAILS ARE PROVIDED FOR STANDARDIZATION PURPOSES ONLY. THIS DETAIL REPRESENTS MINIMUM DESIGN STANDARDS WHICH MAY REQUIRE UPRGRADING FOR SPECIFIC APPLICATIONS.

Green Mountain Water and Sanitation District

STANDARD DETAILS

DATE: 7-15-2005



Detail 15

APPENDIX C
CROSS-CONNECTION CONTROL & BACK FLOW PREVENTION

The following information is quoted from the Colorado Department of Public Health and Environment, Water Quality Control Division:

Article 12 Hazardous Cross-Connection

12.1 Control of Hazardous Cross-Connections

A public water system or a consecutive distribution system of a public water system shall have no uncontrolled cross-connections to a pipe, fixture, or supply, any of which contain water not meeting all applicable provisions of the Colorado Primary Drinking Water Regulations. A supplier of water shall protect the public water system from contamination in the following manner:

- Identify potentially uncontrolled hazardous service cross connections.
- Require system users to install and maintain containment assemblies on any uncontrolled hazardous service cross connections, provided the Department has determined that the assembly is consistent with the degree of hazard posed by the uncontrolled cross connection.
- Installation of containment assemblies shall be approved by the public water system upon installation.
- All containment assemblies shall be tested and maintained as necessary on installation and at least annually thereafter, by a Certified Cross-Connection Control Technician.
- Public water systems shall retain maintenance records of all containment assemblies. Section 1.6.3 requires these records to be available for inspection by Department personnel. All maintenance records shall be kept for three years.
- A public water system shall notify the Department of any cross-connection, as defined in section 1.5.2(29), within 10 calendar days of its discovery. The cross-connection shall be corrected within 10 days of being ordered in writing by the Department to correct the problem. Failure to do so may result in an enforcement order.
- Violations shall be subject to the provisions and penalties prescribed by sections 25-1-114 and 25-1-114.1, Colorado Revised Statutes, and to such other actions as provided by law.

CROSS-CONNECTION CONTROL & BACK FLOW PREVENTION

TABLE OF CONTENTS

SECTION 1 – DEFINITIONS

1.1 DEFINITIONS – GENERAL

1.2 DEFINITIONS – TYPES OF BACKFLOW PREVENTION ASSEMBLIES

SECTION 2 – GENERAL

2.1 CUSTOMER RESPONSIBILITIES

2.2 AFFECTED PROPERTIES

2.3 APPROVED ASSEMBLIES

2.4 TYPE OF PROTECTION REQUIRED

SECTION 3 – INSTALLATION, INSPECTION AND TESTING

3.1 INSTALLATION REQUIREMENTS

3.2 MAINTENANCE

3.3 TESTING, INSPECTION AND ACCEPTANCE

3.4 TEST MONTH MODIFICATION

SECTION 4 – COMPLIANCE AND ENFORCEMENT

4.1 ENFORCEMENT

SECTION 5 – DRAWINGS

SECTION 1 – DEFINITIONS

1.1 DEFINITIONS – GENERAL: Unless the context specifically indicates otherwise, the meaning of the terms used herein shall be as follows:

Approved: The term “approved” is used in reference to a backflow prevention assembly or method shall mean such assembly or method approved by the District as being in compliance with all applicable specifications and requirements of these Rules and Regulations.

Approved Testing Laboratory: The Foundation for Cross-Connection Control and Hydraulic Research of the University of Southern California (FCCC&HR) and the American Society of Sanitary Engineers (ASSE).

Auxiliary Water Supply: Any water supply on or available to any premises other than the public potable water supply. These auxiliary water supplies may include, but not be limited to, water from another utility’s potable water system or from any source such as a well, spring, river, pond, lake, reservoir, stream or any other body of water.

Backflow: The undesirable reversal of the direction of flow of water or mixtures of water and other liquids, gases, or other substances into a potable water system from any source or sources caused by backpressure and/or backsiphonage.

Backflow Prevention Assembly: Any assembly or method designed and used to prevent backflow into a potable water system.

Backpressure: Backpressure occurs when the pressure of the non-potable system exceeds the positive pressure in the water distribution lines; that is, the water pressure within an establishment’s plumbing system exceeds that of the water distribution system. For example, there is a potable water connection to a hot water boiler system that is not protected by an approved backflow preventer. If pressure in the boiler system increases to a point that it exceeds the pressure in the water distribution system, a backflow from the boiler to the public water system may occur.

Backsiphonage: Backsiphonage occurs when there is a partial vacuum (negative pressure) in a water supply system, which draws the water from a contaminated source into a potable water supply. The water pressure within the distribution system falls below that of the plumbing system it is supplying.

Certified Cross-Connection Control Technician: A person who has proven his or her competency to the satisfaction of the Colorado Department of Health and who is listed by the Department of Health as a certified cross-connection control technician.

Check Valve: a valve that permits flow in one direction only.

Contamination: An impairment of the quality of potable water by sewage, industrial fluids, waste liquids, compounds, or any other materials, solids, gases, or liquids to a degree which may create a health hazard or pollution.

Contaminate: Any substance that may impair the quality of water in such a way as to create a health hazard or pollution.

Cross-Connection: Any unprotected actual or potential physical connection or structural arrangement of piping or fixtures between a Customer's water system and the District potable water system through which it is possible to introduce into any part of the District potable water system any used water, industrial fluid, gas, liquid, solid or any other substance other than the intended potable water with which the system is supplied.

Degree of Hazard: The level of risk or potential risk to the public health and the type of adverse effect that the hazard may have upon the District potable water system.

District: Green Mountain Water and Sanitation District.

Health Hazard: Any condition, assembly, or practice in a Customer water system and its operation which could create, or in the judgment of the District or the Colorado Department of Health, may create a danger to the public health and well-being.

Non-testable Assembly: Backflow prevention assemblies not approved by the FCCC&HR because of not being in-line testable.

Pollution: An impairment of the water quality to a degree which does not create a health hazard but which does adversely and unreasonably affect the aesthetic qualities of the potable water supply for domestic use.

Potable Water: Water from any source which has been investigated by the health agency having jurisdiction, and which has been approved for human consumption.

Potable Water System: Any system used for the transmission, storage and use of potable water. This system includes all pipes, conduits, tanks, receptacles, fixtures, equipment, and all other appurtenances used to transmit, store or use potable water.

District Potable Water System: The District potable water system, which shall include all sources, facilities, and appurtenances from the source to the point of delivery of potable water to the Customer, such as valves, pumps, conduits, pipes, tanks, receptacles, fixtures, equipment, and all other appurtenances used to convey and store potable water for public consumption or use.

Service Connection: The terminal end of a service connection to the District potable water system, being the downstream end of the corporation-stop valve where the District loses control over the water at its point of delivery to the Customer water system. "Water service connection" shall also include service connections from a fire hydrant and all other temporary or emergency service connections from the District potable water system.

Used Water: Any water which has been supplied by the District potable water system and has passed through water service connection into a consumer water system and is no longer under the control of the District.

Vacuum: Any pressure less than atmospheric pressure.

1.2 DEFINITIONS – TYPES OF BACKFLOW PREVENTION ASSEMBLIES: Unless the context specifically indicates otherwise, the meaning of the terms used herein shall be as follows:

Air-Gap Separation: A physical separation between the free-flowing discharge end of a District potable water system pipeline and an open or non-pressure receiving vessel. An approved air-gap separation shall be at least double the diameter of the supply pipe measured vertically above the flood-level rim of the vessel, but in no case less than one inch.

Reduced Pressure Principle Assembly: An assembly containing two independently acting, approved check valves together with a hydraulically operating, mechanically independent pressure differential relief valve located between the check valves and at a point below the first check valve. The unit shall include four properly located test cocks and two tightly closing resilient seat isolation valves.

Double Check Valve Assembly: An assembly of two single, independently acting, approved check valves. The unit shall include four properly located test cocks and two tightly closing resilient seat isolation valves. A single check valve or two single check valves linked in tandem is not considered an approved backflow prevention assembly.

Pressure Vacuum Breaker Assembly: An assembly containing one or two independently operating, internally loaded check valves and an independently operating loaded air-inlet valve located on the discharge side of the check valves and fitted with two properly located test cocks and two resilient seat isolation valves.

Atmospheric Pressure Vacuum Breaker Assembly: An assembly containing a shut-off valve followed by a valve body containing a float-check, a check seat and an air-inlet port.

Non-testable Assemblies: Non-testable assemblies that are approved by the ASSE shall only be used for single-family residential applications and are limited to the following:

- a. **Dual Check with atmospheric Vent:** A double check valve assembly with an atmospheric vent located between the two check valves.
- b. **Standard Residential Dual Check:** Same as the dual check with atmospheric vent assembly, but it does not have an intermediate atmospheric vent.
- c. **Hose Connection Vacuum Breaker:** A specialized version of the atmospheric vacuum breaker which attaches between sill cock and hose. Cannot be used as protection from backpressure.

SECTION 2 – GENERAL

2.1 CUSTOMER RESPONSIBILITIES

The Customer shall be responsible for preventing pollution and contaminants from the Customer's water system from entering the District potable water system at the water service connection by installing, operating, maintaining approved backflow prevention assemblies,

having such backflow prevention assemblies tested and inspected and submitting the results of such test to the District's Cross-Connection Control office all as required by the District's Rules and Regulations and explained in more detail below.

2.2 AFFECTED PROPERTIES

Commercial Properties: All commercial properties are required to have backflow prevention assemblies installed and tested at least annually.

Residential Properties: Most residential properties do not need backflow prevention assemblies, however, in some instances based on plumbing code requirements a backflow prevention assembly may be required. More information can be found by contacting the City of Lakewood inspector's office. Although not required by the state, the District encourages homeowners with irrigation systems to test their systems annually to make sure that dirt, bacteria, or chemicals from the lawn cannot enter into the homeowner's drinking water.

Multifamily Residences: Multifamily Residences (or "commercial-residential" properties as they are sometimes referred to) are required to have backflow prevention assemblies based on the similarity between the degree of hazard associated with the multi-family residence and the degree of hazard associated with a commercial property. For example, a multi-unit property with a fire line or a boiler (that uses chemicals like glycol) would have to have a backflow prevention device installed and tested. A single story duplex with a furnace and a water heater would not have to have a backflow prevention assemblies.

2.3 APPROVED ASSEMBLIES

All back flow assemblies, regardless of installation as part of new construction or replacement of an existing backflow prevention assembly must be submitted by the contractor to the District and approved by the District prior to installation.

Only those backflow prevention assemblies described in FCCC&HR's most current "List of Approved Backflow Prevention Assemblies" and such other backflow prevention assemblies approved by the District for use as hereinafter set forth in these Rules and Regulations shall be used.

The entire backflow prevention assembly including the isolation valves furnished as part of the backflow prevention assembly shall meet the design and performance specifications of and be approved by the FCCC&HR.

All backflow prevention assemblies must be readily accessible for in-line maintenance and testing.

2.4 TYPE OF PROTECTION REQUIRED

Unless otherwise specified in these Rules and Regulations, Customers shall install a Reduced Pressure Principal Assembly.

Any other type of backflow prevention assembly may be considered based on the degree of hazard and must be approved by the District prior to installation. For example, a double check assembly for a fire system that uses no chemicals may be a practical application. These assemblies will include an approved double check valve assembly, pressure vacuum breaker assembly, atmospheric vacuum breaker assembly, and a spill resistant vacuum breaker assembly.

SECTION 3 – INSTALLATION

3.1 INSTALLATION REQUIREMENTS:

All backflow prevention assemblies, regardless of installation as part of new construction or replacement of an existing backflow prevention assembly, must be submitted by the contractor to the District and approved by the District prior to installation.

Backflow prevention assemblies shall be installed at the meter, at the property line of the premises, or at any other location designated by the District.

Backflow prevention assemblies shall only be installed in conformance with these Rules and Regulations or in such other manner as approved in advance of installation by the District.

The provisions for these Rules and Regulations shall apply to all existing Customer water systems as well as to all Customer water systems coming into existence after the adoption of these Rules and Regulations.

All backflow prevention assemblies shall be installed in an accessible location and with adequate clearances in accordance with accepted design standards to facilitate maintenance, inspection, testing and repair. All reduced pressure principle and double-check valve assemblies installed in a confined area should maintain minimum clearances as follows:

Minimum 12 inches and maximum 36 inches above finished floor or final grade.

Minimum 12 inches from the adjacent or back wall.

Minimum 24 inches from the opposing or facing wall.

Minimum 24 inches above the assembly.

Adequate clearance shall be provided at each end for operation of valves and/or repair of the backflow prevention assembly.

All backflow prevention assemblies shall be installed in a horizontal position unless advance approval has been obtained from the District for installation in a vertical orientation.

In no case is it permissible to have connections or tees installed on the water service line between the meter and the backflow prevention assembly except that irrigation system supply lines with an approved backflow prevention assembly may be connected to the potable water service line between the water meter and the backflow prevention assembly provided the tee or connection from the water service line is external (outside) and buried.

Isolation valves furnished as part of the backflow prevention assembly shall not be used as the inlet or outlet valve of the meter. Test cocks shall not be used as supply connections.

Approved backflow prevention assemblies shall be installed without any bypass, unless the bypass line is also protected by an approved backflow prevention assembly providing an equivalent degree of protection.

Buried stop and waste valves upstream of backflow prevention assemblies shall not be permitted in any system. Stop and waste valves installed upstream of backflow prevention assemblies are permitted above grade in basements, crawl spaces or in the yard, provided they do not have a usable hose connection.

An approved reduced pressure principle assembly shall not be installed in any below-grade pit or vault unless there is a drain sized twice the nominal pipe diameter of the assembly and which drain discharges to daylight.

An approved double check valve assembly may be installed in below-grade pits or vaults provided these pits or vaults are properly constructed in accordance with accepted design standards and insulated and/or heated to prevent freezing.

An approved pressure vacuum breaker assembly shall be installed with the critical level (C/L) of the assembly a minimum of 12 inches above the highest point of downstream usage. It shall be installed in an upright position and in locations where the pressure vacuum breaker assembly may be subjected to continuous pressure but in no event shall the pressure vacuum breaker assembly be subjected to backpressure or become submerged.

An approved atmospheric pressure vacuum breaker assemblies shall be installed as follows with the critical level (C/L) of the atmospheric pressure vacuum breaker assembly a minimum of 6 inches above the flood-level rim of the vessel being protected or the highest point of use. It shall not be used in installations where the atmospheric pressure vacuum breaker assembly would be submerged or subjected to continuous static line pressure or backpressure or be installed where it would be under pressure for more than 12 hours in any 24-hour period.

3.2 MAINTENANCE:

Backflow prevention assemblies shall be repaired, overhauled or replaced by the Customer at the Customer's expense whenever the backflow prevention assemblies are found to be defective. Any existing backflow prevention assembly installed on a Customer's premises that is not approved by an approved testing laboratory shall be tested every 120 days, and upon failure of any valve within the assembly, the backflow prevention assembly shall be replaced within a period of 10 days with an approved backflow prevention assembly as required by these Rules and Regulations.

Only those replacement and/or repair parts produced or specifically recommended by the manufacturer of the backflow prevention assembly shall be used in the repair of the assembly. Any other repair parts utilized shall be considered a modification of the factory design, and the backflow prevention assembly shall be considered unapproved.

3.3 TESTING, INSPECTION and ACCEPTANCE:

Except as provided below, it shall be the duty of the Customer at any premises where backflow prevention assemblies are required to be installed by these Rules and Regulations, to have such backflow prevention assemblies tested and inspected at least annually by a certified technician to assure the backflow prevention assembly is functioning properly.

1. Non-testable assemblies that are approved under these Rules and Regulations for use in single-family residences are exempt from this testing and inspection requirement.
2. Testable backflow prevention assemblies installed for the lawn sprinkler systems of single-family residences, where there is no injection or mixing of fertilizer or any foreign substance shall be exempt from the annual testing requirements. However, these backflow prevention assemblies shall be tested upon installation, repair, replacement or at least every three years. If the hazard is deemed great enough, the District may require a more frequent testing schedule.

Backflow prevention assemblies shall not be considered as accepted under these Rules and Regulations until a certified inspection and test is made on the installed backflow prevention assembly and the backflow prevention assembly has passed such inspection and testing.

The inspections and tests shall be at the expense of the Customer and shall be performed by a certified technician. All testing gauges used by certified technicians shall be checked for accuracy at least yearly, and proof of compliance shall be submitted to the District upon request.

Certified tests and inspections of backflow prevention assemblies shall occur at least annually. In those instances where the degree of hazard is deemed to be great enough, the District may require that certified inspections and operational tests be performed at more frequent intervals.

Records of all tests, inspections, repairs of backflow prevention assemblies shall be kept by the Customer and by the certified technician for a period of three years after such tests, inspections and/or repairs. The certified technician shall file with the District a copy of the records of all such tests, inspections and/or repairs, within 10 days of completion. In addition, the Customer shall provide the District with copies of such records if requested by the District.

"Passed" test reports must be submitted to the District's Cross-Connection Control office within 10 days.

"Failed" test reports must be verbally reported to the Cross-Connection Control office within 24 hours and the written reports must be submitted within 3 days. Failed backflow prevention assemblies must be repaired or replaced and then retested. Depending on the hazard, the District may require repairs/ replacement be done immediately to prevent contamination.

To contact the District's Cross-Connection Control office use one of the following methods:

Telephone:	303-985-1581
Facsimile:	303-985-0680

E-Mail: backflow@greenmountainwater.org
Place the words “**Backflow Concerns**” in the subject line of your email.

Mailing Address: 13919 W. Utah Avenue
Lakewood, Colorado 80228
Attn: Cross-Connection Control

3.4 TEST MONTH MODIFICATION:

Backflow prevention assemblies are required to be tested and inspected at least annually (every 12 months). Therefore, if a Customer wishes to modify the month when a backflow prevention assembly test and inspection is due, a backflow prevention assembly may need to be tested twice in the first year in which the test month is modified. For example, if the current test month is April, the backflow prevention assembly is due to be tested in July, and the requested change is to October, then the device will have to be tested in July to fulfill its original annual testing requirement and then again in October to establish the new testing cycle. Some customers with multiple backflow prevention assemblies choose to modify the test month in order to group all their testing and inspection to only one month out of the year.

SECTION 4 – COMPLIANCE

4.1 FAILURE TO COMPLY:

If any Customer of the District fails to comply with any provision of these Rules and Regulations, the District may discontinue water service to the Customer until the Customer is in compliance with these Rules and Regulations in accordance with Chapters 8 and 9 of these Rules and Regulations.

4.1 ENFORCEMENT:

Inspection: The Customer’s system will be subject to inspection the District at all reasonable times to determine whether cross-connections or other structural or sanitary hazards exist.

Suspension of Service: If any Customer of the District fails to comply with any provision of these Rules and Regulations, the District may discontinue water service to the Customer until the Customer is in compliance with these Rules and Regulations in accordance with Chapters 8 and 9 of these Rules and Regulations. Non-compliance includes, but is not limited to, failure to install, test and/or maintain a backflow prevention assembly or if a backflow prevention assembly has been removed or bypassed.

SECTION 5 – DRAWINGS

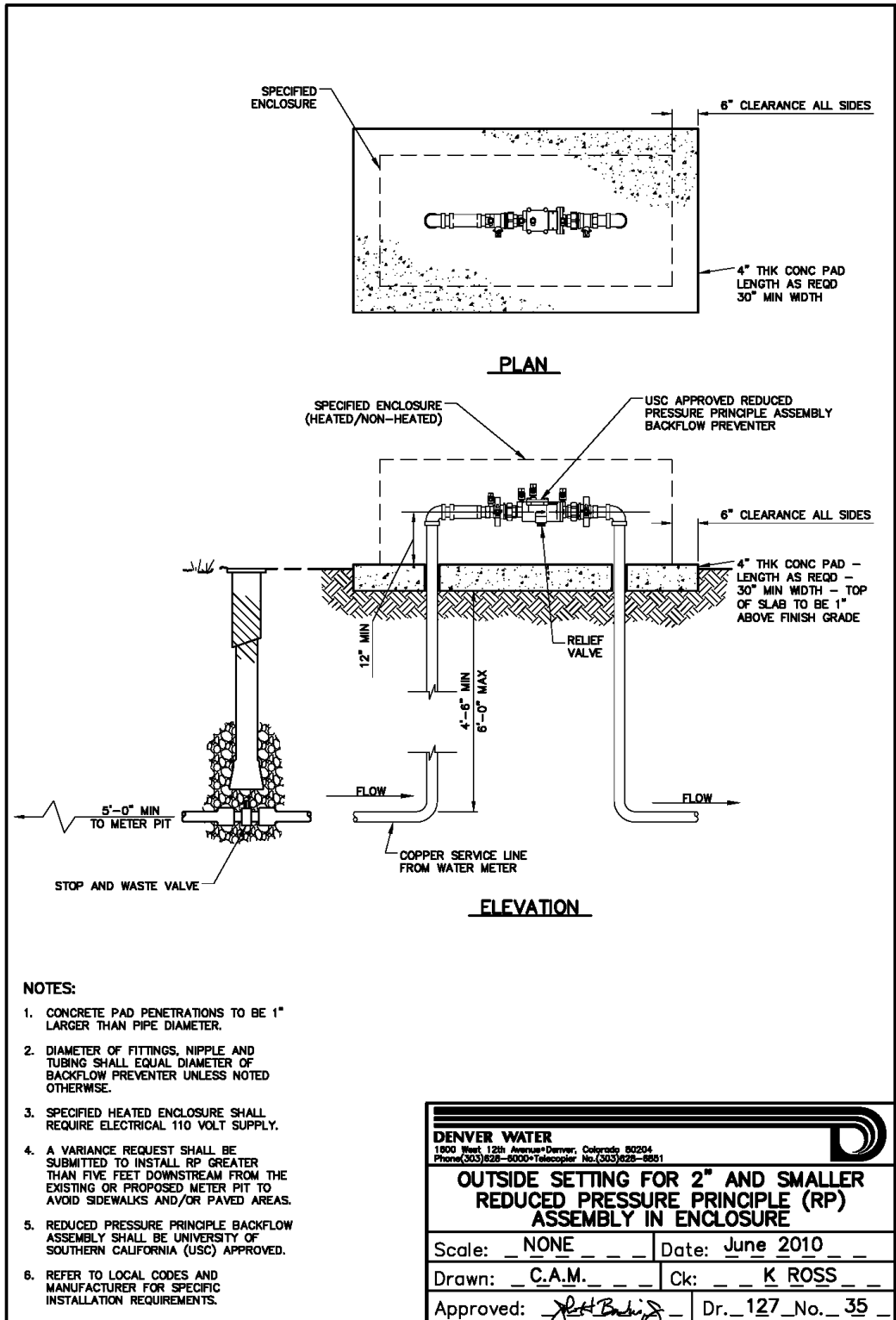

Effective Date: September 2010

SHEET 63

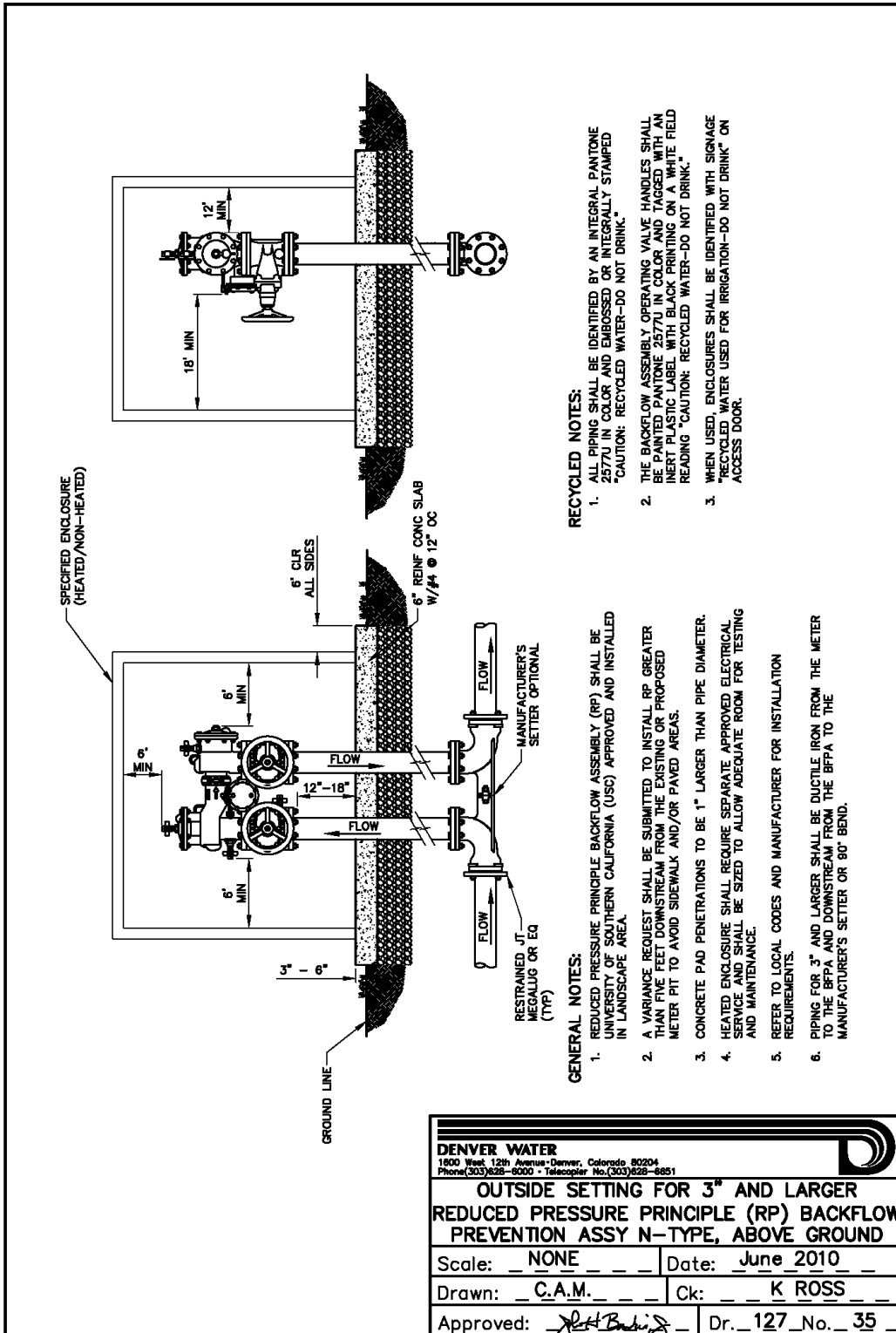

RECYCLED NOTES:

1. ALL PIPING SHALL BE IDENTIFIED BY AN INTEGRAL PANTONE 2577U IN COLOR AND EMBOSSED OR INTEGRALLY STAMPED "CAUTION: RECYCLED WATER-DO NOT DRINK."
2. THE BACKFLOW ASSEMBLY OPERATING VALVE HANDLES SHALL BE IDENTIFIED BY A PANTONE 2577U IN COLOR AND EMBOSSED WITH THE WORD "CAUTION: RECYCLED WATER-DO NOT DRINK" ON THE FIELD READING "CAUTION: RECYCLED WATER-DO NOT DRINK."
3. WHEN USED, ENCLOSURES SHALL BE IDENTIFIED WITH SIGNAGE "RECYCLED WATER USED FOR IRRIGATION-DO NOT DRINK" ON ACCESS DOOR.

GENERAL NOTES:

1. REDUCED PRESSURE PRINCIPLE BACKFLOW ASSEMBLY (RP) SHALL BE UNIVERSITY OF SOUTHERN CALIFORNIA (USC) APPROVED AND INSTALLED IN LANDSCAPE AREA.
2. A VARIANCE REQUEST SHALL BE SUBMITTED TO INSTALL RP GREATER THAN FIVE FEET DOWNSTREAM FROM THE EXISTING OR PROPOSED METER PIT TO AVOID SIDEWALK AND/OR PAVED AREAS.
3. CONCRETE PAD PENETRATIONS TO BE 1" LARGER THAN PIPE DIAMETER.
4. HEATED ENCLOSURE SHALL REQUIRE SEPARATE APPROVED ELECTRICAL SERVICE AND SHALL BE SIZED TO ALLOW ADEQUATE ROOM FOR TESTING AND MAINTENANCE.
5. REFER TO LOCAL CODES AND MANUFACTURER FOR INSTALLATION REQUIREMENTS.
6. PIPING FOR 3" AND LARGER SHALL BE DUCTILE IRON FROM THE METER TO THE BPPA AND DOWNSTREAM FROM THE BPPA TO THE MANUFACTURER'S SETTER OR 90° BEND.

DENVER WATER 1800 West 12th Avenue • Denver, Colorado 80204 Phone (303) 628-6000 • Telecopier No. (303) 628-6851	
OUTSIDE SETTING FOR 3" AND LARGER REDUCED PRESSURE PRINCIPLE (RP) BACKFLOW PREVENTION ASSY N-TYPE, ABOVE GROUND	
Scale: <u> NONE </u>	Date: <u> June 2010 </u>
Drawn: <u> C.A.M. </u>	Ck: <u> K ROSS </u>
Approved: <u> <i>[Signature]</i> </u>	Dr. <u> 127 </u> No. <u> 35 </u>

Effective Date: September 2010

SHEET 64

CONC MH BASE BEAMS REQD FOR METER IN ST OR PARKING AREA (SEE DET SHT 22)

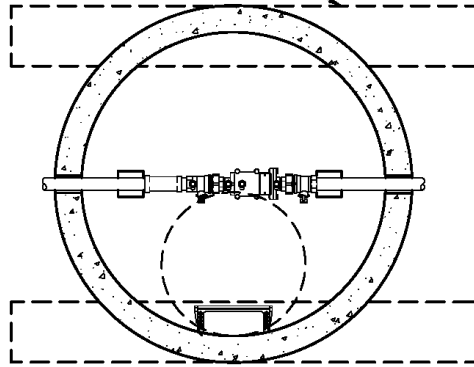

PLAN

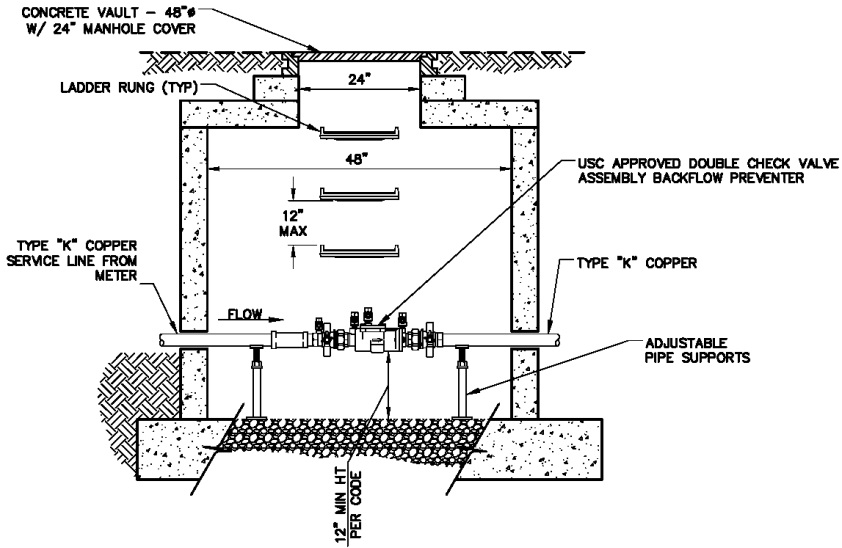

ELEVATION

NOTES:

1. VAULT WALL PENETRATIONS TO BE 1" LARGER THAN PIPE DIAMETER AND CAULKED OR GROUTED.
2. DIAMETER OF FITTINGS, NIPPLE AND TUBING SHALL EQUAL DIAMETER OF BACKFLOW PREVENTER UNLESS NOTED OTHERWISE.
3. DOUBLE CHECK BACKFLOW ASSEMBLY SHALL BE UNIVERSITY OF SOUTHERN CALIFORNIA (USC) APPROVED.
4. REFER TO LOCAL CODES AND MANUFACTURER FOR SPECIFIC INSTALLATION REQUIREMENTS.
5. DISTANCE BETWEEN RUNGS, CLEATS, AND STEPS SHALL BE NOT EXCEED 12" AND SHALL BE UNIFORM THROUGHOUT THE LENGTH OF THE LADDER

DENVER WATER <small>1600 West 123rd Avenue • Denver, Colorado 80204 Phone (303) 628-6000 • Telecopier No. (303) 628-6851</small>	
OUTSIDE SETTING FOR 1 1/2" & 2" DOUBLE CHECK (DC) VALVE ASSEMBLY IN MANHOLE	
Scale: <u>NONE</u>	Date: <u>June 2010</u>
Drawn: <u>C.A.M.</u>	Ck: <u>K ROSS</u>
Approved: <i>[Signature]</i>	Dr. <u>127</u> No. <u>35</u>

Effective Date: September 2010

SHEET 62

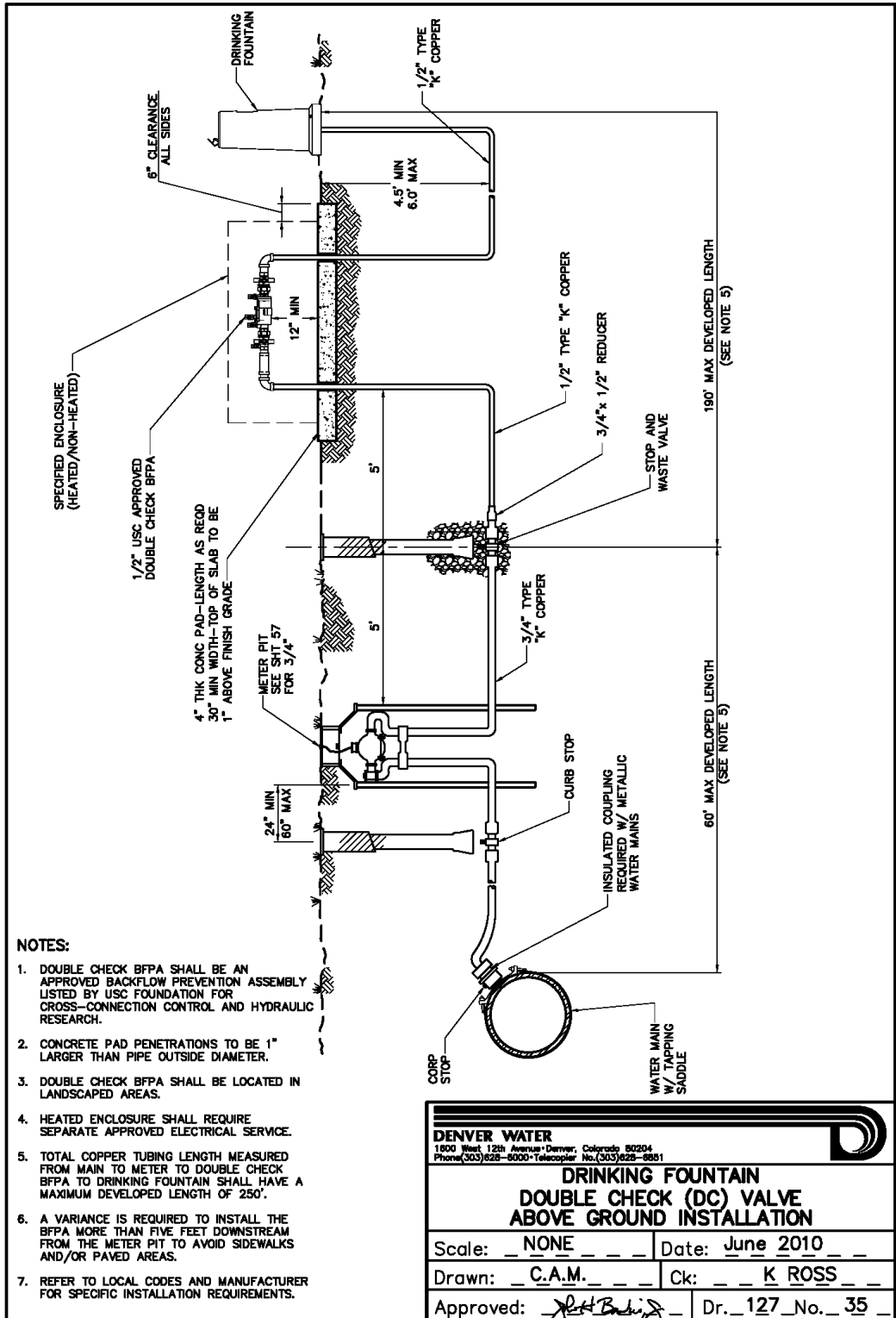

NOTES:

1. DOUBLE CHECK BFFA SHALL BE AN APPROVED BACKFLOW PREVENTION ASSEMBLY LISTED BY USC FOUNDATION FOR CROSS-CONNECTION CONTROL AND HYDRAULIC RESEARCH.
2. CONCRETE PAD PENETRATIONS TO BE 1" LARGER THAN PIPE OUTSIDE DIAMETER.
3. DOUBLE CHECK BFFA SHALL BE LOCATED IN LANDSCAPED AREAS.
4. HEATED ENCLOSURE SHALL REQUIRE SEPARATE APPROVED ELECTRICAL SERVICE.
5. TOTAL COPPER TUBING LENGTH MEASURED FROM MAIN TO METER TO DOUBLE CHECK BFFA TO DRINKING FOUNTAIN SHALL HAVE A MAXIMUM DEVELOPED LENGTH OF 250'.
6. A VARIANCE IS REQUIRED TO INSTALL THE BFFA MORE THAN FIVE FEET DOWNSTREAM FROM THE METER PIT TO AVOID SIDEWALKS AND/OR PAVED AREAS.
7. REFER TO LOCAL CODES AND MANUFACTURER FOR SPECIFIC INSTALLATION REQUIREMENTS.

DENVER WATER <small>1500 West 12th Avenue • Denver, Colorado 80204 Phone (303) 628-8000 • Telecopier No. (303) 628-8881</small>	
DRINKING FOUNTAIN DOUBLE CHECK (DC) VALVE ABOVE GROUND INSTALLATION	
Scale: <u> NONE </u>	Date: <u> June 2010 </u>
Drawn: <u> C.A.M. </u>	Ck: <u> K ROSS </u>
Approved: <u> <i>[Signature]</i> </u>	Dr. <u> 127 </u> No. <u> 35 </u>

Effective Date: September 2010

SHEET 55

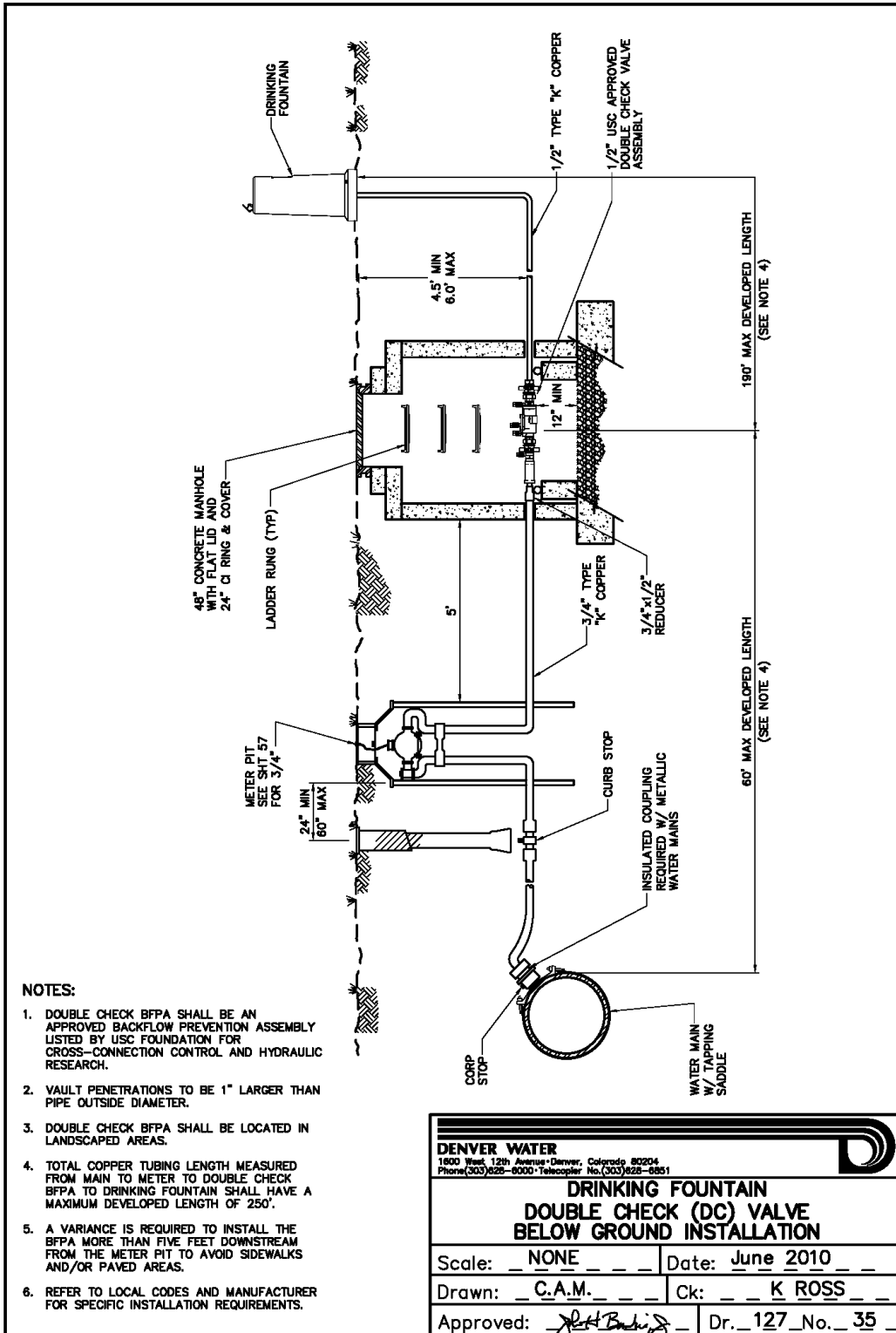

NOTES:

1. DOUBLE CHECK BPPA SHALL BE AN APPROVED BACKFLOW PREVENTION ASSEMBLY LISTED BY USC FOUNDATION FOR CROSS-CONNECTION CONTROL AND HYDRAULIC RESEARCH.
2. VAULT PENETRATIONS TO BE 1" LARGER THAN PIPE OUTSIDE DIAMETER.
3. DOUBLE CHECK BPPA SHALL BE LOCATED IN LANDSCAPED AREAS.
4. TOTAL COPPER TUBING LENGTH MEASURED FROM MAIN TO METER TO DOUBLE CHECK BPPA TO DRINKING FOUNTAIN SHALL HAVE A MAXIMUM DEVELOPED LENGTH OF 250'.
5. A VARIANCE IS REQUIRED TO INSTALL THE BPPA MORE THAN FIVE FEET DOWNSTREAM FROM THE METER PIT TO AVOID SIDEWALKS AND/OR PAVED AREAS.
6. REFER TO LOCAL CODES AND MANUFACTURER FOR SPECIFIC INSTALLATION REQUIREMENTS.

DENVER WATER <small>1600 West 12th Avenue • Denver, Colorado 80204 Phone (303) 628-6000 • Telecopier No. (303) 628-6851</small>	
DRINKING FOUNTAIN DOUBLE CHECK (DC) VALVE BELOW GROUND INSTALLATION	
Scale: <u> NONE </u>	Date: <u> June 2010 </u>
Drawn: <u> C.A.M. </u>	Ck: <u> K ROSS </u>
Approved: <u> <i>[Signature]</i> </u>	Dr. <u> 127 </u> No. <u> 35 </u>

Effective Date: September 2010

SHEET 56

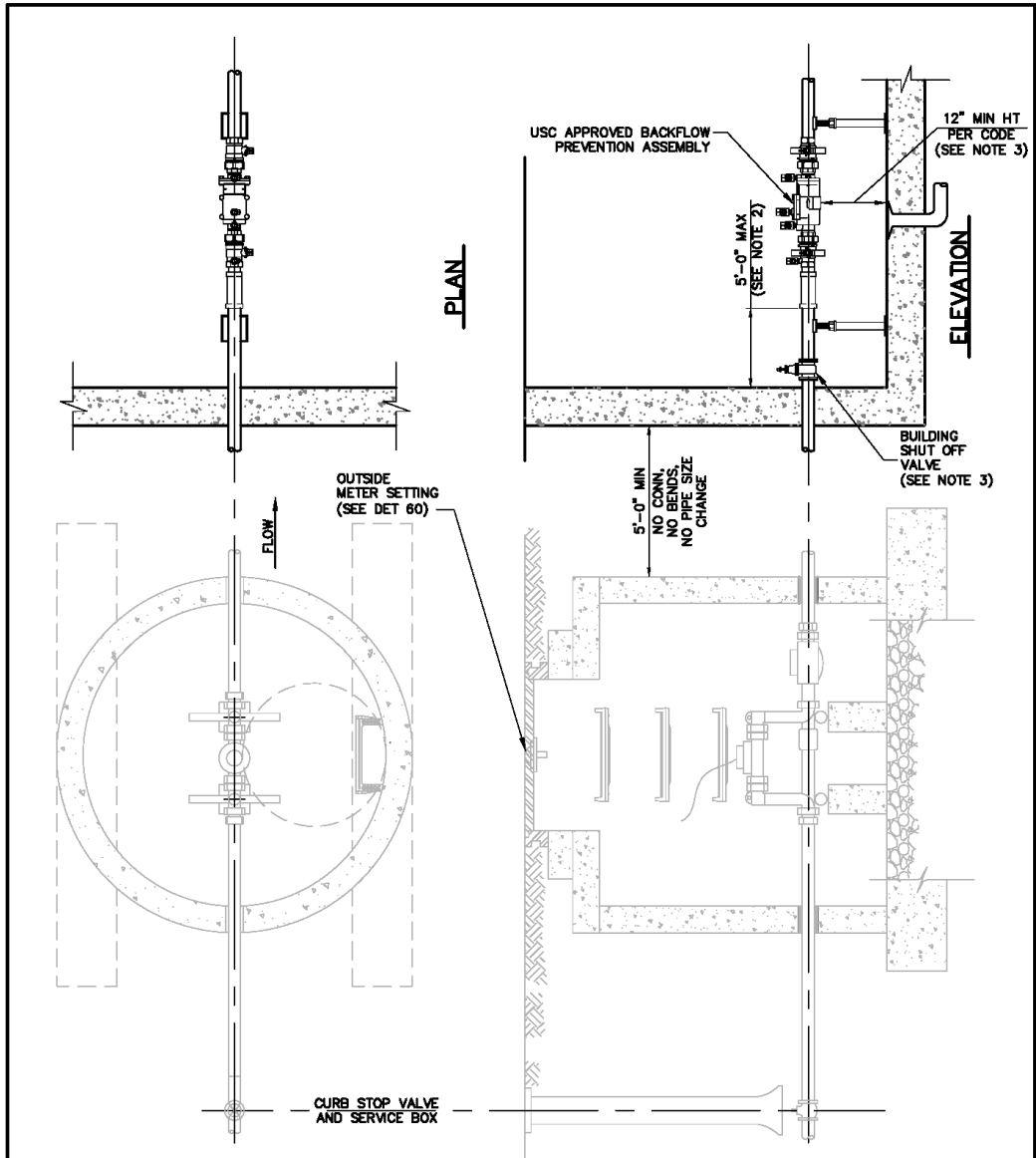

NOTES:

1. USC APPROVED DOUBLE CHECK VALVE OR REDUCED PRESSURE PRINCIPLE BACKFLOW PREVENTION ASSEMBLY DETERMINED BY DEGREE OF HAZARD POSED BY INTERNAL PLUMBING USE.
2. PLACEMENT OF BFPA CAN VARY A MAXIMUM OF 5 FT FROM THE INSIDE WALL OF BUILDING.
3. REFER TO LOCAL CODES AND MANUFACTURER FOR SPECIFIC INSTALLATION INSTRUCTIONS.
4. INSTALL SUPPORTS WITHIN 12" OF THE INLET AND OUTLET ISOLATION VALVES
5. SEE SHEET 53 FOR ADDITIONAL NOTES

DENVER WATER <small>1500 West 123rd Avenue • Denver, Colorado 80204 Phone (303) 628-8000 • Telecopier No. (303) 628-8881</small>	
OUTSIDE SETTING FOR 1 1/2" AND 2" METER & BYPASS IN MANHOLE WITH INSIDE BACKFLOW PREVENTION ASSEMBLY	
Scale: <u>NONE</u>	Date: <u>June 2010</u>
Drawn: <u>C.A.M.</u>	Chk: <u>K ROSS</u>
Approved: <i>[Signature]</i>	Dr. <u>127</u> No. <u>35</u>

Effective Date: September 2010

SHEET 61

APPENDIX D

Water and Sewer Main Testing Procedures

FLUSHING, TESTING, AND DISINFECTING WATER MAINS: (up-date)

- A. Pipeline Flushing: The Contractor shall flush the pipelines as the work progresses by a means in accordance with good practice to insure that sand, rocks or other foreign material are not left in any of the pipelines. If possible, the flushing shall be made through an open pipe end; otherwise, use of a fire hydrant may be acceptable, but only on approval of the Engineer.

14. Pressure Test: After each section of pipeline has been laid and partially backfilled (except for the joints or when the Engineer directs the trench to be backfilled for reasons of public safety, or if the Contractor elects to backfill prior to testing, as permitted), the pipe shall be slowly filled with water and tested. All pipe shall be tested at a pressure of 150 psi at the lowest point in each section. Each section shall be tested separately, but outside transmission mains may be tested in convenient lengths. The duration of each pressure test shall be at least one continuous hour. All water used in testing the pipelines shall be taken from a potable water supply.

Each section of pipeline being tested shall be slowly filled with water and all air removed. The specified test pressure shall be applied by means of a pump connected to the pipe in a manner satisfactory to the Engineer. The Contractor shall furnish all necessary labor, equipment, connections, and corporation stops to the pipeline to perform the test.

No testing shall be permitted against valves or fittings that are a part of the existing system unless specifically approved by the Engineer.

All exposed pipes, fittings, valves, hydrants, and joints will be carefully examined during the test. Any cracked or defective pipe, fittings, valves or hydrants discovered during the pressure test shall be removed and replaced by the Contractor with sound material. The test shall be repeated until it is satisfactory to the Engineer.

- C. Leakage Test: A leakage test shall be conducted after the pressure test has been completed unless the pressure test indicates that there are no leaks. The Contractor shall furnish the pump, pipe, connections, meters, and all other necessary apparatus, and shall furnish all necessary assistance to conduct the test. The duration of each leakage test shall be two hours, and, during the test, the main shall be subjected to a hydrostatic pressure of 150 pounds per square inch.

No pipeline installation will be acceptable until the leakage is less than the amount computed by the following formula:

1. DIP, PVC $L = SD(P)^{0.5} 133,200$

- L = Allowable leakage in gallons (per hour)
- S = Tested length of pipe (feet)
- D = Nominal diameter of pipe (inches)
- P = Average test pressure during the test (psi)

Should any test of pipe laid disclose leakage greater than that specified above, the Contractor shall, at his own expense, locate and repair the points of leakage until the leakage is within the specified allowance.

The pipe may be subjected to hydrostatic pressure, inspected, and tested for leakage at any convenient time after the trench has been partially backfilled, except at the joints, or backfilled as permitted by the Engineer. Where any section is provided with concrete thrust blocks, the pressure test shall not be made until at least two days have elapsed after the concrete was installed.

The Inspector shall be notified at least 48 hours before the pipe is to be tested so that he may be present during the test.

- 15. Disinfecting: All water piping installed under this Contract shall be disinfected in accordance with AWWA C601 after all construction work has been completed. Chlorine shall be added to the water at the necessary locations in the amount to form a 50 ppm free chlorine residual. The chlorine solution shall be left in the pipelines for not less than 24 hours, during which time all valves and fire hydrants shall be operated in order to disinfect the appurtenances. After that length of time, the chlorine residual of the solution at any place in the system shall not be less than 10 ppm. As required, the Contractor shall make all necessary taps for inserting the chlorine solution in the pipeline and venting and draining pipelines using approved corporation stops. After the disinfection has been completed and approved, the corporation stops shall be closed, left in place, and sealed with a cap. All chlorination work must be done under the supervision of the Inspector. At the end of 24 hours, a bacteriological test is to be performed by the local health authority to insure adequate disinfection.

After approval of the disinfection operations, the Contractor shall flush the new system until the chlorine residual is 0.3 ppm and a clear water test made.

FLUSHING AND TESTING SEWER PIPELINES:

- A. Pipeline Flushing: The Contractor shall flush the pipelines, as the work progresses, by means that are in accordance with good practice, to insure that earth, sand, rocks or other foreign materials are removed from the interior of the pipeline. The preferred method for this is to jet clean the new sewer line with equipment designed for this purpose.

- B. Alignment and Grade: Sewer pipelines will be checked by the Inspector to determine whether any displacement of the pipe has occurred after the trench has been bedded to an elevation 6 inches above the pipe and tamped as specified. The test will be as follows:

A light will be flashed between manholes, or if the manholes have not as yet been constructed, between the locations of the manholes, by means of a flashlight or by reflecting sunlight with a mirror. If the illuminated interior of the pipeline shows poor alignment, displaced pipe, earth, or other debris in the pipe, or any other kinds of defects, the defects, determined by the Engineer, shall be remedied by the Contractor at his own expense. The test will be repeated following completion of backfilling and any poor alignment, displaced pipe, or other defects, determined by the Engineer, shall be corrected at the Contractor's expense. The preferred method of inspecting new lines is to video camera the sewer line and record tap locations and footages. A video tape and written report will be required. The contractor shall use equipment specifically designed for this type of work or have the work contracted out at his expense. Please see Appendix D, pages 7 and 8.

Curved sewers shall be cleaned with a heavy rubber ball after the pipe has been laid and the backfill has been placed. The rubber ball shall be similar and equal to a "Mac Wane Ball," as manufactured by the Sidu Company, Long Beach, California. The ball shall be inflated and the outside diameter shall be the same as the inside diameter of the sewer pipe. The ball shall be placed at the upper manhole of the sewer reach to be cleaned. A head of water shall be placed against the ball to force the ball through the sewer, and debris flushed from the line shall be collected at the lower manhole, or its location. The ball shall be secured by a line to control the rate at which the ball is allowed to pass through the sewer.

16. Leakage: Tests for water tightness shall be made by the Contractor in the presence of the Engineer. The Contractor shall provide assistance to the Engineer in development of a detailed record of the testing program. The sewer and connections shall not leak in excess of the following rate for a 24-hour test period:

MAXIMUM ALLOWABLE SEWER LEAKAGE

Pipe Size Inches	Leakage Gal/Foot/24 Hours
36	1.36
30	1.14
27	1.02
24	0.91
21	0.80
18	0.68
15	0.57
12	0.45
10	0.38
8	0.30

Each reach of pipeline between manholes shall be tested individually. Any individual reach that leaks in excess of the amount allowed in the previous paragraph shall be considered as failing, and shall be repaired and retested.

At the discretion of the Engineer, the time for leakage rate test may be shortened to four (4) hours.

The tests and measurement of infiltration or exfiltration shall be conducted in a manner as approved by the Engineer. The Contractor shall repair the sewer in a manner that is satisfactory to the Engineer and re-test until satisfactory tightness is obtained.

Infiltration tests will be used if the groundwater table is 1 foot or more above the finished sewer; otherwise, exfiltration tests will be used. The minimum head for the exfiltration tests shall be 2 feet above the top of the pipe at its highest point in the test section. Sections shall be bulk-headed so that during any test the head on the sewer at its lowest elevation will not be more than 10 feet. This restriction does not apply to ductile-iron pipe. In any section of the pipeline if the head at the lowest point in the section exceeds 10 feet, then the Engineer will set forth the special method of testing to meet the field conditions.

Air tests for sewer lines may be substituted for leakage tests at the option of the Contractor. The air tests will be conducted in the presence of the engineer, or his authorized representative, in accordance with the guidelines and standards set by Uni-Bell Plastic Pipe Association.

The Contractor will use equipment specifically designed for air testing sewers. The air test shall be made when the sewer is clean and lateral services properly plugged. The line shall be plugged at each manhole with pneumatic balls and low pressure air may be introduced through either end. The air shall fill the plugged line until the internal pressure is 3.5 psig greater than the average back pressure of any groundwater pressure that may submerge the pipe. (This pressure to be determined in the field by the Engineer, but not to exceed 9.0 psig). At least two (2) minutes shall be allowed for the air temperature to stabilize, then the internal pressure shall be allowed to drop to the test pressure. At this point the internal line pressure is monitored. The line pressure shall not drop more than 0.5 psig in less time than specified in the table or the pipe fails the test and shall be repaired and retested. The Contractor is responsible for locating the leaks, repairing them, and re-testing the line.

Air Test C Minimum Time Pressure Loss

Pipe Diam. (In)	Minimum Time Length Pipe (Min:Sec)	Pipe (Ft)	Time Longer for Length (Sec)
8	3:47	298	.760 L
10	4:43	239	1.187 L
12	5:40	199	1.709 L

15	7:05	159	2.671 L
18	8:30	133	3.846 L
21	9:55	114	5.235 L
24	11:20	99	6.837 L

- D. Deflection: All PVC sewer pipelines shall be tested for vertical deflection after placement and compaction of backfill unless testing is specifically accepted by the Engineer. Method of testing shall be by deflectometer of the rigid GO/No-GO type device. An alternative method will be permitted only by written permission of the Engineer or as defined in the Special Construction Provisions of these Specifications. Maximum allowable deflection shall be five (5) per cent of the pipe diameter.
- E. Any and all pipe with vertical deflection greater than the allowable shall be excavated, removed from the pipeline, replaced, backfilled and compacted as specified, and retested at the Contractor's expense.

TESTING MANHOLES: During the construction of the manholes, the Contractor shall, in accordance with good practice, insure that no earth, sand, rocks or other foreign material exists on the joint surfaces during assembly of the sections. The Inspector shall check each manhole to determine whether the manhole fulfills the requirements of the Drawings and Specifications. The Visual Examination and either the Leakage Test or Vacuum Test are required.

- A. Visual Examination: The Engineer shall visually check each manhole, both exterior and interior, for flaws, cracks, holes, or other inadequacies which might affect the operation or watertight integrity of the manhole. Should any inadequacies be found, the Contractor shall make any repairs deemed necessary by the Engineer.
- B. Leakage Test: All manholes shall be tested for leakage and all tests shall be witnessed by the Engineer. The leakage test shall be conducted prior to backfilling around the manhole and shall be carried out in the following manner:
 1. All lines leading into or out of the manhole shall be tightly plugged.
 2. The manhole shall be filled with water to a level at least 2 inches above the uppermost step. The water shall be allowed to stand for two hours to allow for normal water absorption into the manhole material. At the end of the two-hour stabilization period, if the water level in the manhole has dropped below the top step, additional water will be added to bring the level above the step as before. Any visible external leakage or drop in water level noted within the one-hour test period shall constitute failure, and the Contractor, as his own expense, shall repair the manhole and re-test until satisfactory watertightness is obtained.
- C. Vacuum Testing: All pipes entering and exiting the manhole shall be temporarily plugged, taking care to securely brace the pipes and plugs to prevent them from being drawn into the manhole.

The test head shall be placed at the top of the manhole and the seal inflated in accordance with the manufacturer's recommendations.

A vacuum of 10-inches of mercury shall be drawn on the manhole, the valve on the vacuum line of the test head shall be closed, and the vacuum pump shut-off. The time shall be measured for the vacuum to drop to 9-inches of mercury.

The minimum test time shall be one minute. If the manhole fails the initial tests, the manhole shall be repaired and re-tested until a satisfactory test is obtained.

The manhole will be declared unacceptable if the time to drop from 10-inches of mercury to 9-inches of mercury is less than the time shown in the following table:

DEPTH (FEET) (Vertical Length of Manhole)	TIME (seconds)		
	48" Diameter	60" Diameter	72" Diameter
8	20	26	33
10	25	33	41
12	30	39	49
14	35	46	57
16	40	52	67
18	45	59	73
20	50	65	81
22	55	72	89
24	59	78	97
26	64	85	105
28	69	91	113
30	74	98	121

VIDEO INSPECTION EQUIPMENT AND OPERATION

EQUIPMENT

All equipment required for work in this specification shall be in good repair with no defects adversely affecting the rate of progress, the quality of the monitor's picture, or the quality of recording.

The television camera and lighting system shall be specifically designed and constructed for pipeline inspection. The camera shall be mounted on adjustable skids, wheels or runners to keep it centered in the pipe.

The view seen by the television camera shall be transmitted to a monitor located inside a mobile TV studio. The monitor shall be capable of receiving the same number of lines or more of resolution as the camera transmits.

The television inspection system shall be capable of televising 500 feet between manholes in a straight or gradually curved sewer.

Measurement for location of defects shall be from center line of the manhole at ground level by means of a metering device so that the point of observation will be known at all times. Measurement devices which require an interpolation for depth of manhole will not be allowed.

Measurement meters shall be accurate to plus or minus 0.2 feet over the length of sewer line being inspected. Accuracy of the measurement device shall be verified daily. The measurement meter shall have a zero reset and shall add and subtract. The measurement meter shall be located so as to be easily read on the monitor and on recordings.

The Contractor shall furnish all equipment and materials required for making digital recordings.

OPERATION

The operation of the TV inspection system shall be controlled by the monitoring technician at the TV control panel.

Particular care shall be taken in viewing the pipeline immediately adjacent to each manhole.

Special note shall be taken if unusually uniform and uncontaminated flow comes from any particular lateral line.

Written records shall be kept by the Contractor and shall clearly show the exact location, in relation to the center of adjacent manholes, of points of significance such as location of laterals, open joints, broken pipe, non-uniform pipe slope or alignment, estimated depth of flow, extent of puddling, and other features of interest.

The Contractor will clearly indicate the location and nature of any pictures and recordings made as part of the record. A good reproducible copy of all records shall be supplied to the Owner.

In the event a piece of televising equipment becomes lodged in the pipe, the Contractor shall notify the Owner, and be responsible for all costs associated with extracting the equipment. The Owner will not pay for damage to the Contractor's cleaning equipment.

APPENDIX E
GREASE INTERCEPTOR AND SAND/OIL INTERCEPTOR

1. GENERAL.

Green Mountain Water and Sanitation District (the “District”) shall require the installation of a pre-treatment device when the strength per unit time and/or constituents of the wastewater discharge into the public sanitary sewer system exceed that which is generally accepted to be “normal domestic wastewater.” The owner of the establishment shall be responsible for installing pre-treatment devices adequate to pre-treat the establishment’s sewage contribution to acceptable standards. If property has been rented or leased, the term “owner” as used in these rules and regulations refers to the owner, renter or lessee, and the owner, renter and lessee shall be jointly and severally liable for all duties imposed under these rules and regulations.

The District shall require the installation of a grease interceptor and/or sand/oil interceptor, at the sole cost and expense of the owner of the establishment when, in the opinion of the District, a grease interceptor and/or sand/oil interceptor is necessary for the proper handling of liquid wastes containing grease or oil in excessive amounts, any flammable wastes, sand, or other harmful constituents.

Establishments that provide food service, food preparation, food catering, meat cutting, animal slaughtering and other operations capable of discharging grease into the public sanitary sewer system shall be required to install a grease interceptor.

Establishments that provide automotive repair services, truck and car wash facilities, vehicle maintenance facilities, machine shop facilities and other establishments capable of discharging grease, oil, sand and/or flammable wastes into the public sanitary sewer system shall be required to install a sand/oil interceptor.

When a pre-treatment device is required, it shall be based on one of the following determination methods:

- (a) Direct sample. A direct sample shall be used whenever required. A sample taken at a monitoring point shall be analyzed and tested by the owner at the direction of the District.
- (b) Comparison. A comparison with other businesses or industrial establishments that use similar processes and which the District has determined discharge wastewater of a similar nature, composition and volume to that of the establishment in question.
- (c) Best Judgment. Best judgment shall be made where it is not possible to sample and where a similar process to which a comparison may be made does not exist. Best judgment shall be made on a reasonable knowledge of the processes involved, the nature of the wastewater produced by such processes and the amount of water consumption.

2. DEFINITIONS.

The following definitions are applicable to pre-treatment devices:

(a) Fixture Unit. A rating in terms of gallons per minute (gpm) representing the maximum amount of water that can drain from a fixture or piece of equipment in one minute. The value of one fixture unit (F.U.) is equal to 7.5 gpm.

(b) Grease Interceptors. Two compartment interceptors normally located outside a building and of a size as approved by the District. (750 gallons to be minimum standard required by the District unless the District approves a deviation from this requirement.)

(c) "In-line" Grease Trap. A prefabricated unit generally made of metal that normally is set indoors under a sink or near the fixture connected to it, for the trapping of grease and oils.

(d) Monitoring Point. A location in the owner/operators sewer service line that is accessible for monitoring, sampling and testing the wastewater flow from an establishment.

(e) Owner. The owner, or renter or lessee if any, of the establishment or property.

(f) Pre-treatment Facilities. Structures, devices or equipment for neutralizing or removing deleterious wastes from wastewater generated by an establishment prior to its discharge into a public sewer.

(g) Sampling. A periodic collection of wastewater as it flows through a sewer.

(h) Sand/Oil Interceptors. Two compartment interceptors normally located outside a building and of a size as approved by the District (750 gallons to be minimum standard required by the District unless the District approves a deviation from this requirement.).

(i) Testing. The analysis of wastewater.

3. PLAN SUBMITTIAL AND PLAN REVIEW.

If any waters or wastes are discharged, or are proposed to be discharged to the public sewers that may potentially contain substances or possess the characteristics enumerated in Section 1, it shall be the responsibility of the owner or authorized representative to contact the District for the purpose of plan submittal. The plan submitted shall specify the need, method, and size of pre-treatment facility required by these rules and regulations to pre-treat, or otherwise control the wastes, to make them acceptable for discharge into the Districts sanitary sewer system. The District may also require that plans be reviewed and approved by Metropolitan Denver Wastewater Reclamation District.

When required by these rules and regulations or by determination of the District to install a grease interceptor or sand/oil interceptor, the owner, renter, or lessee shall submit an interceptor design plan with supporting design criteria to the District, who must approve it prior to installation. The cost of reviewing and approving the plan, and inspection and approval of the installation shall be charged to the owner or applicant. The owner shall make all interceptors available for inspection during the installation process.

The District may require additional plans and/or information to determine the impact on the public sanitary sewer system by the proposed wastes and to assist with calculating the size of the pre-treatment facilities.

4. LIMITATIONS ON WASTEWATER STRENGTHS.

Wastewater discharge into the sanitary sewer system shall not have or contain:

(a) Any water or wastes containing grease, oil, hydrocarbons, fatty acids, soaps, fats or waxes which exceed 100 mg/1 as determined by solvent (Freon) extraction;

(b) Any wastewater capable of raising the Lower Explosive Limit (L.E.L.) of the ambient atmosphere in any sewer to 5% for any two successive readings or to 10% for any single reading on an explosion hazard meter. Prohibited materials include, but are not limited to, gasoline, kerosene, naphtha, benzene, toluene, zylene, ethers, alcohols, ketones, aldehydes, peroxides, chlorates, perchlorates, bromates, carbides, hydrides and sulfides.

Prohibited Cleaning Agents:

All owners are prohibited from cleaning or maintaining their pre-treatment devices with microbial grease digestants, or similar enzyme based additives which allow grease and other wastes to move through the grease interceptors in liquid form into the District's sewer systems.

All owners who use microbial grease digestants, or similar enzyme based additives in violation of this section shall be jointly and severally liable for all costs and expenses associated with cleaning and unclogging the District's sewer system as a result of the discharge of grease in liquid form.

5. PREVIOUSLY INSTALLED PRE-TREATMENT DEVICES.

If it becomes necessary for the District to require an existing business or industrial owner to install suitable waste pre-treatment units, a written explanation for the requirement shall be furnished to the owner or his authorized agent. Such a requirement may arise when it becomes apparent that the existing pre-treatment facility is deficient in size, or waste emanating from the business or industry violates these rules and regulations and/or may cause harm to the public sewer system or to persons entering said system to perform maintenance, or to the treatment process and/or environment.

(a) Exceptions. The owner may request relief of the requirement to replace a previously installed pre-treatment device. The request must include a detailed plan of the proposed method of removing deleterious wastewater constituents. The proposal must assure wastewater discharged into the public sewer system is of "normal domestic strength." Should a conflict arise as to wastewater strength and/or constituents, the burden of proof for determination of strength and/or constituents will rest with the owner.

(1) The District will periodically inspect the facility granted the exception for conformance to the approved plan. Should operations deviate from the approved plan, the District may take whatever

action it deems appropriate, which may include the levying of an administrative fine or the immediate installation of an approved interceptor.

(2) Attachment to and continued use of the public sanitary sewer system is evidence of permission to grant access to District inspectors to determine continued conformance to the approved plan.

6. GREASE INTERCEPTORS.

(a) Location/Design

(1) All grease interceptors shall be constructed of impervious materials capable of withstanding abrupt and extreme changes in temperature. They shall be watertight, and, if necessary, gastight and vented.

(2) All grease interceptors shall be located outside, between 5 feet and 30 feet from the building, unless the District specifically authorizes placement at a different location. The interceptor shall be easily accessible at all times for inspection and maintenance.

(3) All cast-in-place grease interceptors shall be concrete with wall and floors of a single pour. Detailed drawings shall be submitted to the District for review and approval.

(4) In-line grease traps are not permitted unless specifically approved by the District.

(5) Garbage disposal grinders are required to discharge to the grease interceptor.

(6) The minimum grease interceptor capacity shall be 750 gallons (Unless the District approves a smaller size).

(b) Calculating Interceptor Size

Size calculations are to be prepared by the owner and submitted to the District per the following methods:

(1) Where food is prepared and/or served and the seating capacity or number of meals can be determined, compute:

(a) Number of seats x a full capacity factor of 0.9 x turnover rate of 2.2 per meal period = number of meals served per meal period.

(b) Number of meals served per meal period x 2.5 gallons per meal = volumetric water capacity of the grease interceptor.

(2) Where food is prepared and/or served and where seating capacity or number of meals cannot be adequately determined, the following rule shall apply:

(a) Table 1 establishes the fixture unit values for various pieces of equipment that may require connection to a grease interceptor.

(b) The total number of fixture units shall be multiplied by 7.5 gpm to determine maximum rate of flow into the grease interceptor. The volumetric water capacity of the unit shall be 8 times the maximum flow rate.

**TABLE ONE
MINIMUM INTERCEPTOR SIZE**

TYPE OF FIXTURE	INCHES	FIXTURE UNITS
Floor Drains	2"	2
	3"	3
Laundry Tubs	1-1/2"	3
Clothes Washers	2"	2
Receptors (Floor sinks), Indirect waste receptors for Refrigerators, coffee urns, Water stations, etc.	1-1/2"	1
Sinks, bar, private (1-1/2"- Minimum waste)	1-1/2"	2
Receptors, indirect waste Receptors for commercial Sinks, dishwashers, etc.	2"	3
Sinks, commercial or Industrial, schools, etc. (Including dishwashers, Wash-up sinks (2" minimum waste)	2"	3
Sinks, Services	2"	3
Wash basin (Lavatory)		
Single	1-1/4"	2
Wash basins, in sets	1-1/2"	2

The unit equivalent of fixtures and devices not shown on Table 1 shall be based on the rated discharge capacity in G.P.M. in accordance with Table 2.

**TABLE 2
Discharge Capacity (in G.P.M.) For Intermittent Flow Only**

0 – 7.5 G.P.M.	=	1 Fixture Units (F.U.)
8 – 15 G.P.M.	=	2 Fixture Units (F.U.)
16 – 30 G.P.M.	=	4 Fixture Units (F.U.)
31 – 50 G.P.M.	=	6 Fixture Units (F.U.)

Note: For a continuous flow into a drainage system, two F.U. shall be assumed for each gpm of flow.

7. SAND/OIL INTERCEPTORS.

(a) Location/Design

(1) All sand/oil interceptors shall be constructed of impervious materials capable of withstanding abrupt and extreme changes in temperature. They shall be watertight, and, if necessary, gastight and vented.

(1) All sand/oil interceptors shall be located outside, between 5 feet and 30 feet from the building, unless the Districts specifically authorize placement at a different location. Interceptors shall be easily accessible at all times for inspection and maintenance.

(2) All cast-in-place sand/oil interceptors shall be concrete with walls and floors of a single pour. Detailed drawings shall be submitted to the District for review and approval.

(3) The minimum sand/oil interceptor capacity shall be 750 gallons. (Unless District approves a smaller size).

(b) Calculating Interceptor Size

Size calculations are to be prepared by the owner and submitted to the District per the following method:

- (1) Total fixture units connected x 7.5 gpm x 5 minutes = interceptor size.
- (2) The total fixture unit values shall be based on the Table 3 on the following page:

TABLE 3

FACILITY	F.U.
Floor Drain:	
3" trap	6
4" trap	8
Vehicle Wash Drain	8
Service Bay with Trough Drain:	
380 S.F. or less	6
381 S.F. through 760 S.F.	12
761 S.F. through 1140 S.F.	18
ETC.	

8. PROPER PUMPING PROCEDURE.

(a) Each grease interceptor or sand/oil interceptor shall be pumped and fully evacuated of all accumulated waste content.

(b) Removal or skimming of only the grease cap layer is prohibited. All grease interceptors shall be pumped entirely clean and dry.

(c) No de-watering or recycle trucks shall be allowed.

(d) Each interceptor shall thoroughly cleaned.

9. MAINTENANCE, WASTE DISPOSAL AND MONITORING.

The owner of any grease interceptor or sand/oil interceptor shall maintain it in good operating condition. It will be the responsibility of the owner to contract with a locally licensed pumping contractor and maintain a record of each pre-treatment device pump out. It is required that each pre-treatment device be inspected and documented on an annual basis by both an independent licensed pumping contractor and a representative from the District. The independent licensed pumping contractor must file the inspection report with the District. Pre-treatment devices must be cleaned on a minimum quarterly basis or more frequently as required by the District.

All pre-treatment device pump out records shall be submitted to the District no later than 10 days after the pumping has been completed. Annual pre-treatment device inspection receipts shall be kept on site and available for review. Failure to do so may result in an additional required pre-treatment device pump out, at the District's discretion.

10. FINANCIAL RESPONSIBILITY.

All maintenance, cleaning and repair within a sewer service line, up to and including the tap, will be the exclusive responsibility of the owner of the property. If a clog or obstruction that occurs in the public sewer main can be traced to a specific property, that property owner shall be liable for paying all or a portion of cleaning and or repair costs.

11. VIOLATIONS AND ENFORCEMENT.

Failure to comply with these rules and regulations shall constitute a violation of the District's rules and regulations. The District's staff may issue citations for non-conforming establishments and set and impose fines for violations up to \$200 a day. The owner in violation may also be liable for additional charges, termination of service, other applicable fees and costs, including costs and attorney's fees for enforcement and such other remedies as the District may deem appropriate. All fines or additional charges will be assessed on the next District service bill for the property.

Prior to termination of service, the District shall provide written notice to the owner, renter, or lessee stating the date of the proposed termination of service and the reasons therefore. The notice shall also provide an opportunity for a hearing before the District board, which shall be conducted in accordance with section 9.5.1 of the District's rules and regulations.

12. PURPOSE AND INTENT.

The purpose and intent of these rules and regulations is to provide certain uniform, minimum standards, procedures, and requirements for the regulation of the pumping out, cleaning, or otherwise servicing of pre-treatment devices, in order to protect the public health, safety, and general welfare.

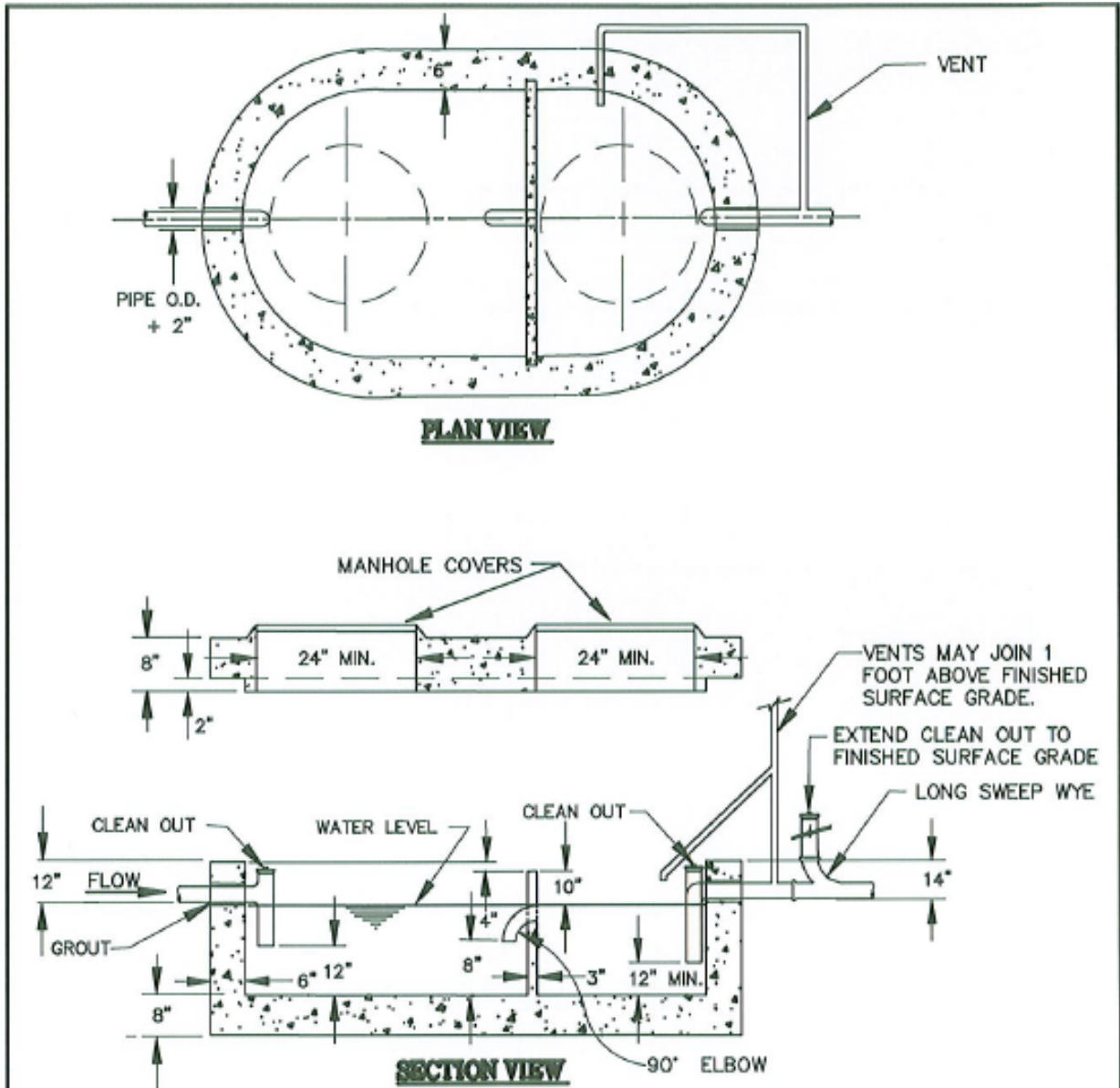

GREASE INTERCEPTOR

N.T.S.

SECONDARY COMPARTMENT VOLUME EQUAL TO $\frac{1}{3}$ TOTAL VOLUME.
 DESIGN AND CONSTRUCTION OF PRECAST INTERCEPTORS SHALL COMPLY WITH THE APPROPRIATE ASTM SPECIFICATION'S.
 INTERCEPTORS SHALL BE DESIGNED TO ACCOMMODATE H-20 LOADING.
 REFER TO DISTRICT STANDARDS, DESIGN CRITERIA AND MATERIALS SPECIFICATIONS FOR ADDITIONAL REQUIREMENTS.
 THESE DETAILS ARE PROVIDED FOR STANDARDIZATION PURPOSES ONLY AND REPRESENT MINIMUM DESIGN STANDARDS WHICH MAY REQUIRE UPGRADING FOR SPECIFIC APPLICATIONS, OR VARY BY MANUFACTURER.
 SUBMIT DESIGN CALCULATIONS AND CERTIFICATIONS SIGNED AND SEALED BY A PROFESSIONAL ENGINEER.

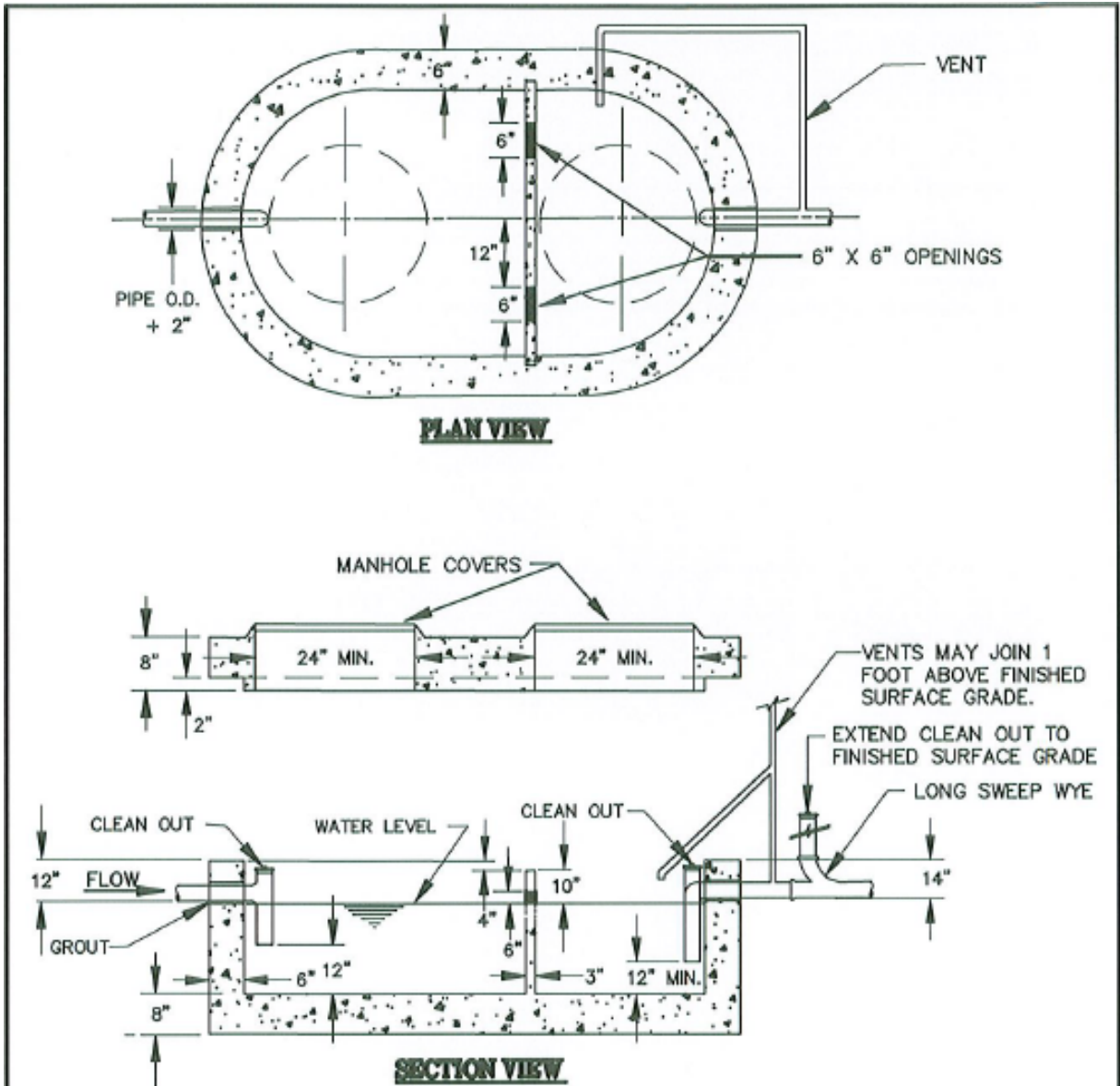

SAND / OIL INTERCEPTOR

N.T.S.

SECONDARY COMPARTMENT VOLUME EQUAL TO 1/3 TOTAL VOLUME.

DESIGN AND CONSTRUCTION OF PRECAST INTERCEPTORS SHALL COMPLY WITH THE APPROPRIATE ASTM SPECIFICATION'S.

INTERCEPTORS SHALL BE DESIGNED TO ACCOMMODATE H-20 LOADING.

REFER TO DISTRICT STANDARDS, DESIGN CRITERIA AND MATERIALS SPECIFICATIONS FOR ADDITIONAL REQUIREMENTS.

THESE DETAILS ARE PROVIDED FOR STANDARDIZATION PURPOSES ONLY AND REPRESENT MINIMUM DESIGN STANDARDS WHICH MAY REQUIRE UPGRADING FOR SPECIFIC APPLICATIONS, OR VARY BY MANUFACTURER.

SUBMIT DESIGN CALCULATIONS AND CERTIFICATIONS SIGNED AND SEALED BY A PROFESSIONAL ENGINEER.

Green Mountain Water and Sanitation District

STANDARD DETAILS

DATE: 1-27-2009



Detail 20